



VIRTUO[®] ONE

VIRTUO[®] MIX

VIRTUO[®] FIT

WBS1P/WBS1PIN 2-41

WBSA2R/WBSA2R2C 42-63

WBSMU/WBSMUEX 64-66



BÂTI-SUPPORT MURAL VIRTUO ONE

avec réservoir 2 volumes économiseur d'eau



Notice de pose

Bâti-support
WBS1P
WBS1P1N



Nicoll
by aliaxis

SOMMAIRE

DESCRIPTION	4
RÉGLAGES DES BÂTIS-SUPPORTS	5
POSE DES BÂTIS-SUPPORTS	6
MONTAGE DE LA PIPE	6
RÉGLAGE DES PIEDS ET DES ÉQUERRES	6
FIXATION ET RACCORDEMENT À L'ÉVACUATION	7
FIXATION DE LA CUVETTE	8
RACCORDEMENT À L'ARRIVÉE D'EAU	9
RÉALISATION DE L'HABILLAGE AVEC PLAQUE OU BOUTON DE COMMANDE	10
COUPE DU TUBE DE RINÇAGE ET DU MANCHON D'ÉVACUATION.....	12
MISE EN PLACE DE LA CUVETTE	13
INSTALLATION DE LA PLAQUE DE COMMANDE	14
INSTALLATION DU BOUTON DE COMMANDE	16
LES OPÉRATIONS DE MAINTENANCE	17
LES PROCÉDURES D'ENTRETIEN	18

English version

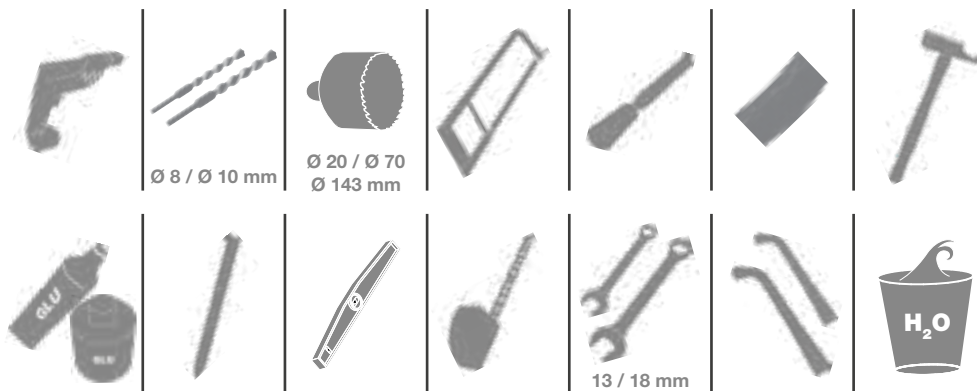

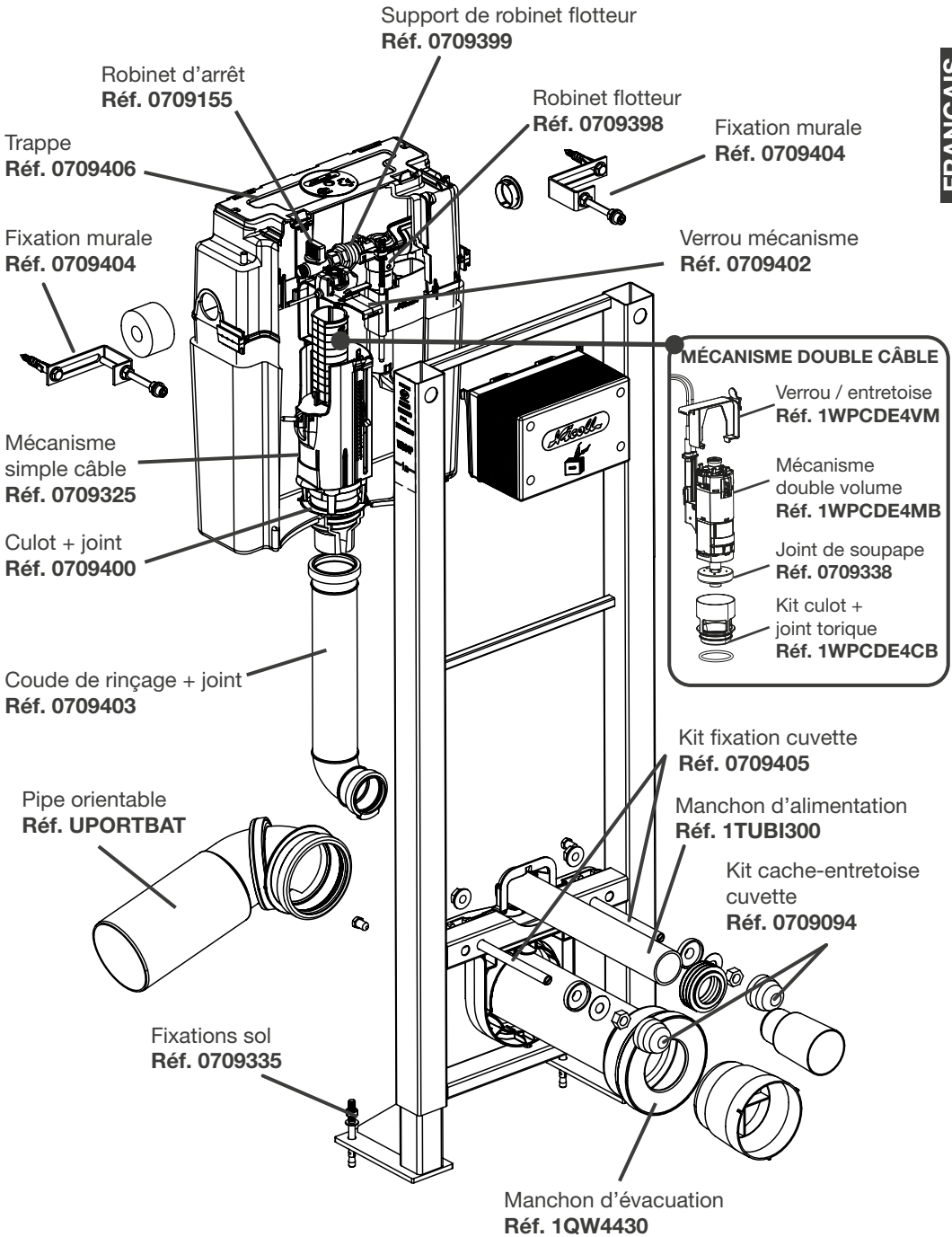

RÉGLAGE DES BÂTIS SUPPORTS



L'installation doit se faire sur un mur porteur.

- A** = 162 - 197 mm
- B** = 15 - 70 mm (plaque de commande)
- B** = 15 - 35 mm (bouton de commande)
- C** = 400 mm (recommandé si compatible avec votre cuvette) ou 450 mm pour personnes à mobilité réduite

Repère de 1 m par rapport au sol fini à respecter pour avoir la cuvette à environ 400 mm du sol.

D = 1093 - 1332 mm

E = 290 - 525 mm

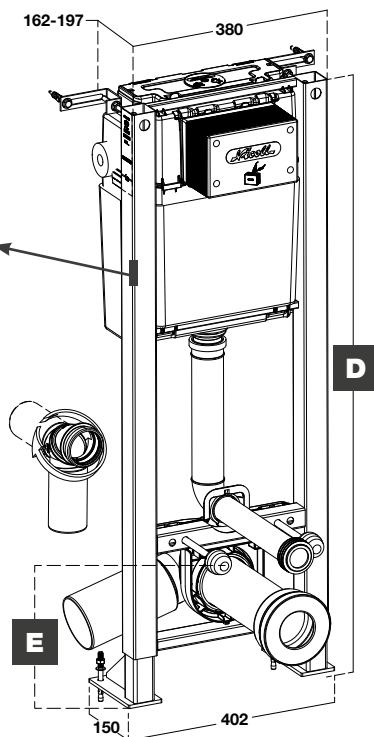

MONTAGE DE LA PIPE

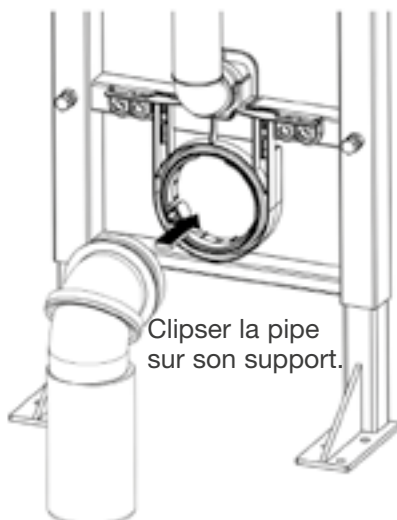

RÉGLAGE DES PIEDS ET DES ÉQUERRES

Après avoir déterminé le bon réglage en hauteur, bloquer les vis pointeau, assembler, régler et fixer les équerres de fixation murales.

1 RÉGLAGE DES PIEDS

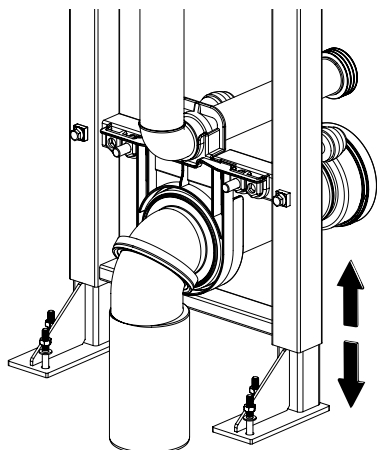

2 RÉGLAGE DES ÉQUERRES

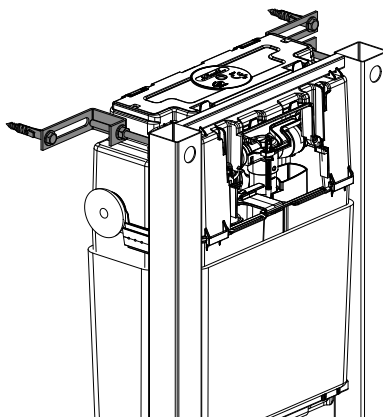

 La position en hauteur de la cuvette sera définitive.

FIXATION ET RACCORDEMENT À L'ÉVACUATION

Ajuster la pipe en recoupant la partie droite si besoin.



Un manchon d'adaptation au diamètre de la canalisation peut-être nécessaire (non fourni).

Présenter le bâti dans sa position définitive pour valider les réglages et pointer l'emplacement des perçages. Percer dans le sol aux emplacements pointés, encoller la pipe et fixer définitivement le bâti

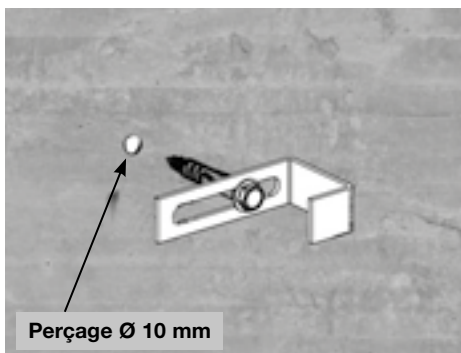
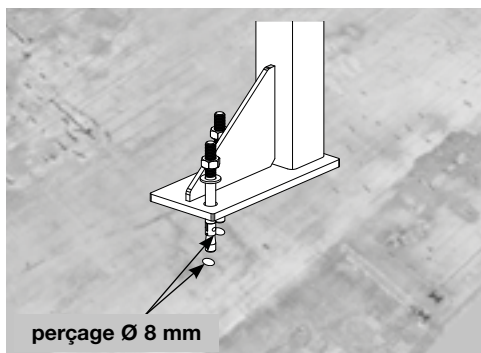
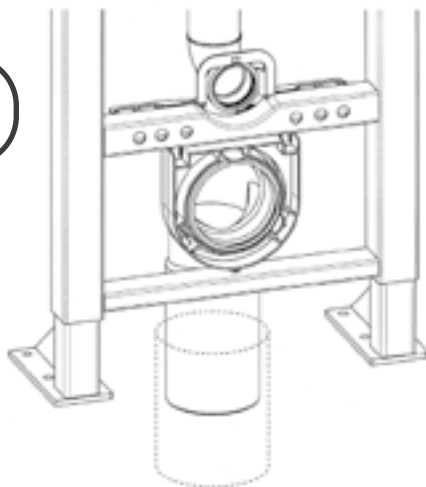

Pipe orientable pour une évacuation droite, verticale ou latérale.

FIXATION DE LA CUVETTE

Choisir l'entraxe des tiges de fixation.

Positionner les 2 écrous M12 à embase en fonction de l'entraxe des tiges de fixation (180 ou 230 mm).

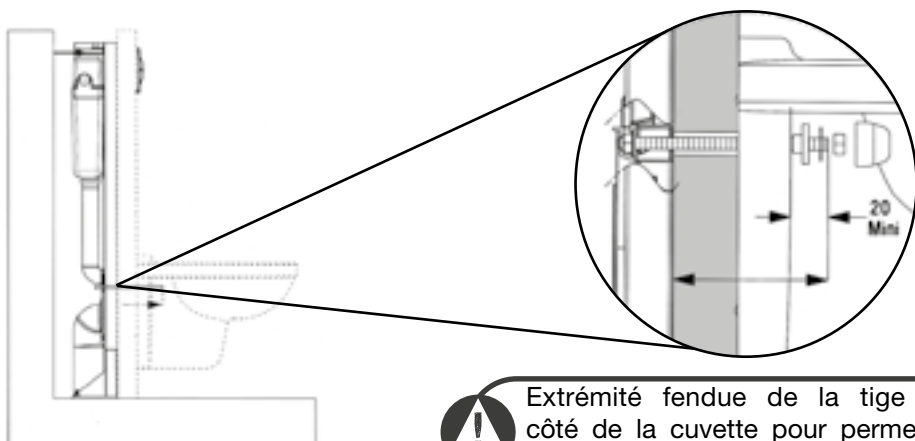
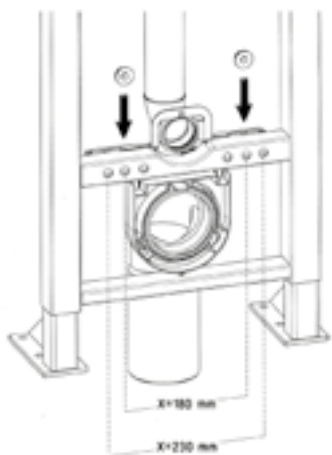

Prévoir l'épaisseur de l'habillage et de la cuvette et rajouter 20 mm pour le réglage de la tige de fixation.

 Extrémité fendue de la tige du côté de la cuvette pour permettre l'ajustement à l'aide d'un tournevis.

RACCORDEMENT DE L'ARRIVÉE D'EAU

Il est conseillé de se raccorder directement sur le robinet d'arrêt.

Si utilisation d'un flexible (non fourni), les deux raccords aux extrémités du flexible doivent être à l'intérieur du réservoir par sécurité en cas de fuite.

L'arrivée d'eau peut se faire par la droite ou la gauche du réservoir en enlevant la rondelle de protection du trou d'alimentation (montée en usine pour une alimentation à gauche).

Se rapporter à la partie maintenance pour permuter le robinet flotteur (p.15).

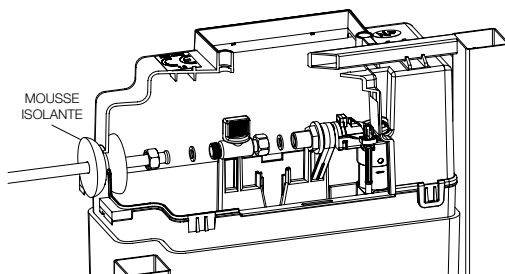

Il faudra également inverser le mécanisme de chasse.

Purge du circuit d'alimentation :
Démonter le robinet flotteur en tirant sur la patte puis en soulevant le robinet et son support.

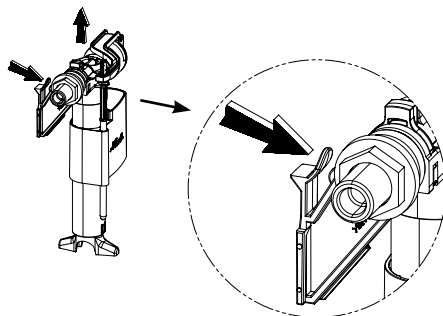

Purger pour évacuer les impuretés éventuelles.

Vérifier l'étanchéité de l'arrivée d'eau et remonter le robinet flotteur.

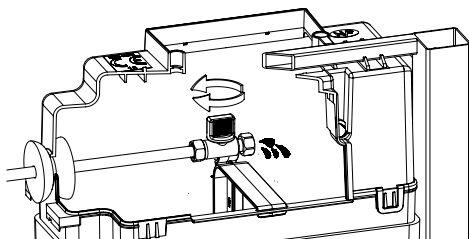

Il est conseillé de tester l'ensemble complet (avec la cuvette et les manchons) pour vérifier les étanchéités avant de réaliser l'habillage (remplacer l'habillage entre le bâti et la cuvette par des cales). Faire quelques cycles complets (remplissage réservoir + chasse).

RÉALISATION DE L'HABILLAGE

1A INSTALLATION AVEC PLAQUE DE COMMANDE

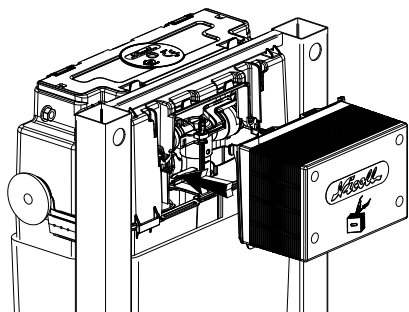

Mettre en place le gabarit.



Réaliser l'habillage à ras du gabarit.

L'épaisseur de l'habillage ne doit pas excéder 70 mm.

Ajouter des cales dans le cas de montage en cloison creuse double paroi.

1B INSTALLATION AVEC BOUTON DE COMMANDE COUPE-FEU RÉF. : WBCCFB / WBCCFC / WBCCFS

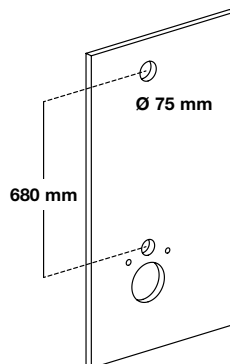
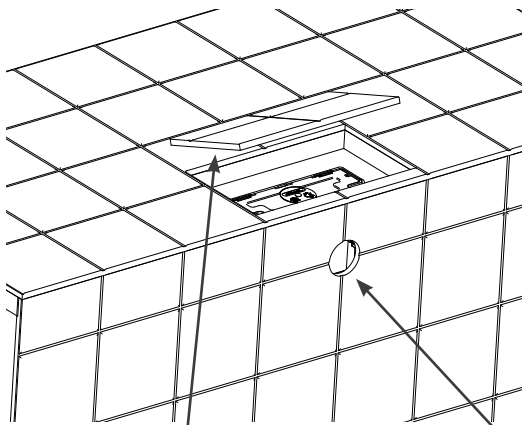

Prévoir une trappe d'accès au réservoir pour toute maintenance éventuelle.

Prévoir un trou de diamètre 75 mm pour la fixation du bouton de commande.

L'épaisseur de l'habillage ne doit pas excéder 62 mm sans rallonge et 117 mm avec rallonge.

Ajouter des cales dans le cas de montage en cloison creuse double paroi.

1C INSTALLATION AVEC BOUTON DE COMMANDE 403L / 404L / 405L

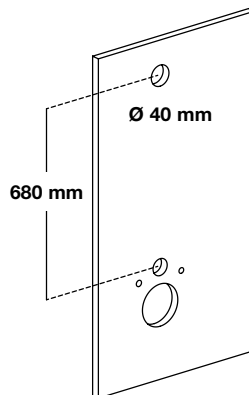
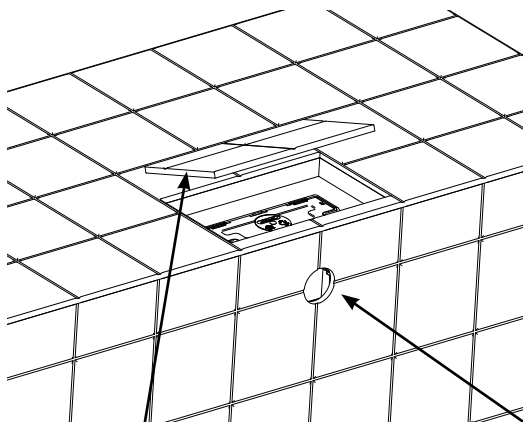

! Prévoir une trappe d'accès au réservoir pour toute maintenance éventuelle.

Prévoir un trou de diamètre 40 mm pour la fixation du bouton de commande.

L'épaisseur de l'habillage ne doit pas excéder 35 mm sans rallonge et 90 mm avec rallonge.

Ajouter des cales dans le cas de montage en cloison creuse double paroi.

2 PROTECTION DES PIPES ET DES TIGES

Mettre en place les protections des tiges filetées (tubes annelés) et les bouchons.

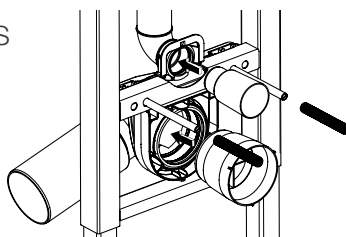

Ce système permet un large choix de finitions personnalisées et la structure de l'habillage peut être réalisée avec de nombreuses solutions :

- avec des carreaux de plâtre, briques, etc.
- avec des panneaux d'aggloméré marine,
- avec 2 plaques de BA13 hydrofuges superposées,
- avec 1 plaque de BA18 hydrofuge.

La pose de l'habillage se fait entre les étapes de la page 9 à 11 de la notice d'utilisation.

APRÈS L'HABILLAGE :

Pour faciliter les opérations des étapes pages 11 et 12 : graisser les joints d'étanchéité de chaque raccord ou tube.

COUPE DU TUBE DE RINÇAGE ET DU MANCHON D'ÉVACUATION

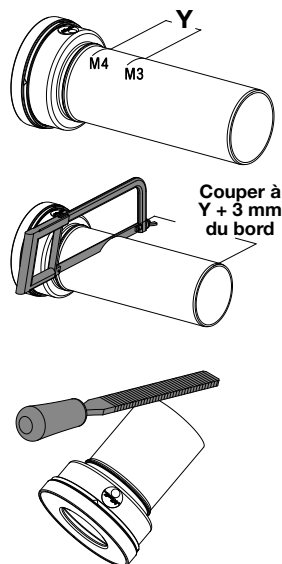
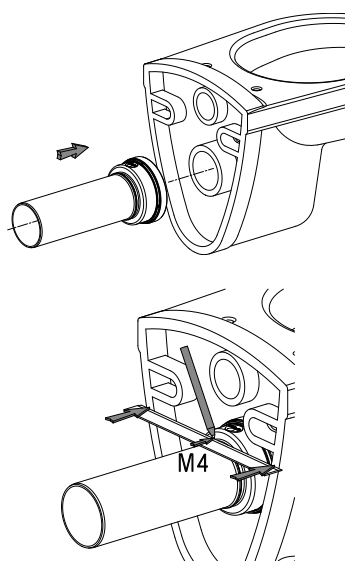
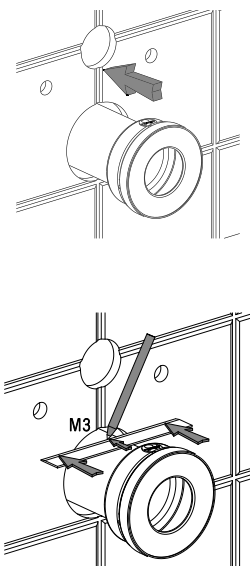
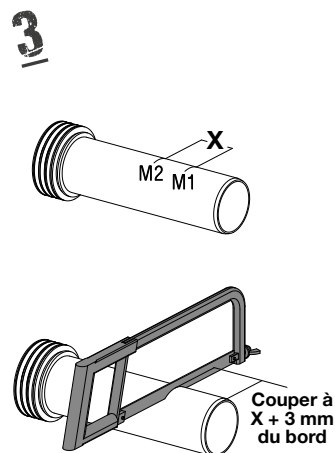
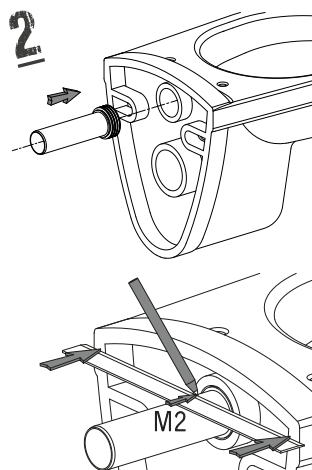
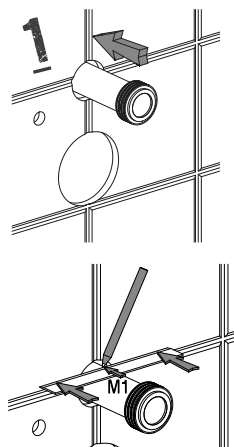

MISE EN PLACE DE LA CUVETTE

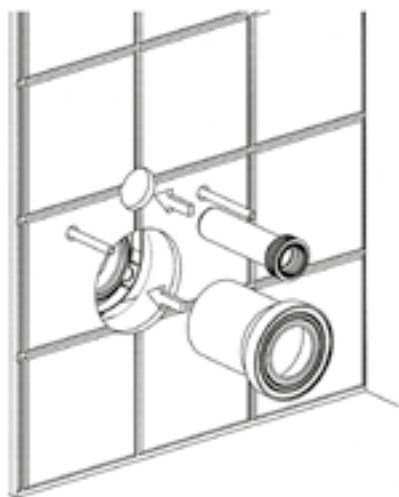

Enfoncer le tube et le manchon sur le bâti à travers l'habillage.

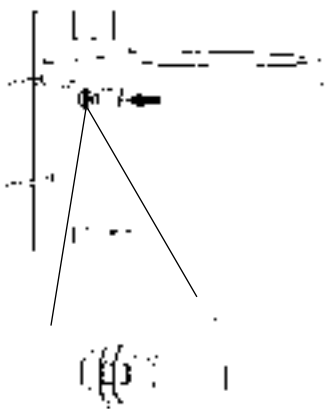

Mettre en place la cuvette sur les tiges de fixation.



Attention, le montage de la cuvette sur une cloison creuse double paroi nécessite la pose de cales ou d'une plaque de renfort.

INSTALLATION DE LA PLAQUE DE COMMANDE

A COUPER LE GABARIT

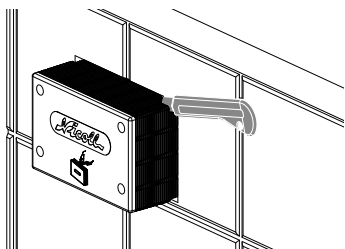

Couper le gabarit à l'aide d'un cutter afin de pouvoir mettre en place le cadre support.

B1 MISE EN PLACE DE PLAQUE DE COMMANDE AVEC MÉCANISME SIMPLE CÂBLE



Mise en place du cadre support :
Séparer les vis du cadre, ébavurer la tête de vis et le cadre.
Introduire les vis en biais comme sur le dessin.
Visser les derniers filets.

Pour plus de détails, se reporter à la notice fournie avec la plaque de commande.

B2 MISE EN PLACE DE PLAQUE DE COMMANDE AVEC MÉCANISME DOUBLE CÂBLE

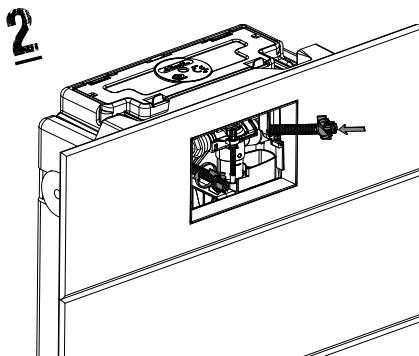
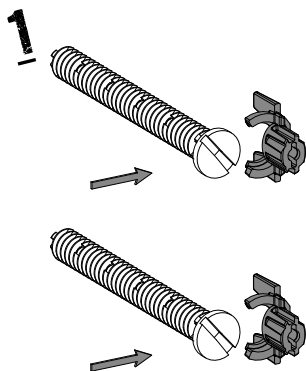

LA POSE DES BÂTIS SUPPORTS

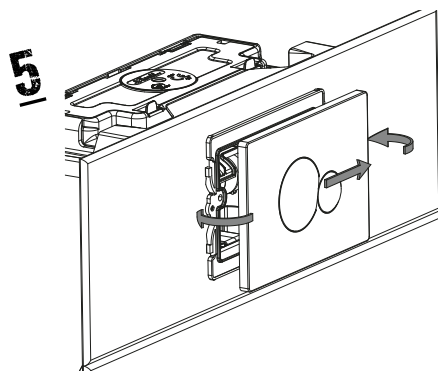
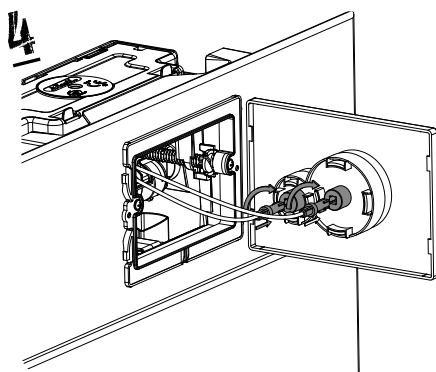
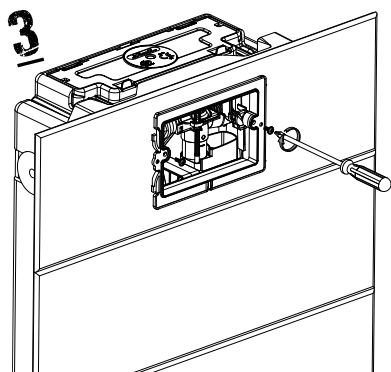

C RACCORDEMENT DE LA PLAQUE DE COMMANDE

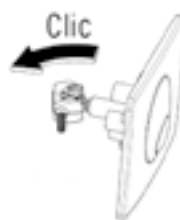
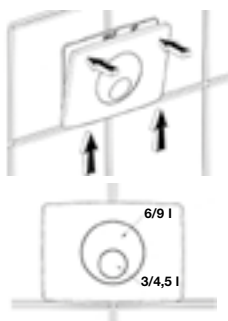
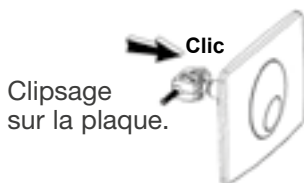

INSTALLATION DU BOUTON DE COMMANDE

Uniquement pour le mécanisme simple câble

1 FIXER LE BOUTON À L'AIDE DE L'ÉCROU

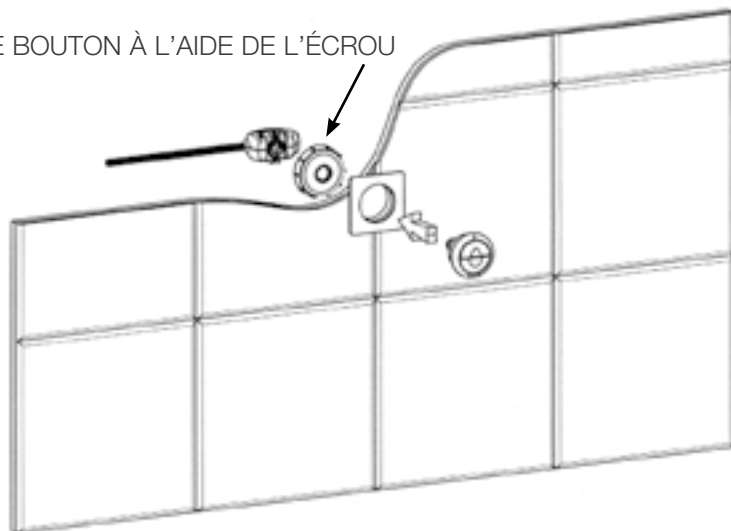

Pour plus de détails, se reporter à la notice fournie avec le bouton de commande.

2 RACCORDEMENT DU BOUTON DE COMMANDE

Clipsage sur le bouton.

Clic

Verrouillage du boîtier de commande.



RÉFÉRENCES WBS1PECO / WBS1PECO2

WBS1PECO

La version WBS1PECO est fournie avec un mécanisme simple câble réglé en usine avec des volumes de chasse d'eau de 3 et 4,5L (configuration non NF).

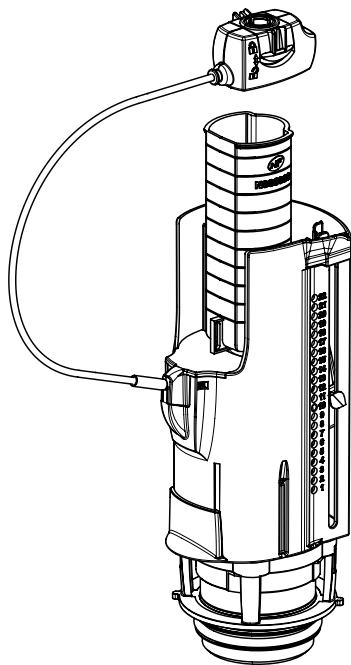

WBS1PECO2

La version WBS1PECO2 est fournie avec un mécanisme double câble réglé en usine avec des volumes de chasse d'eau de 3 et 4,5L (configuration non NF).

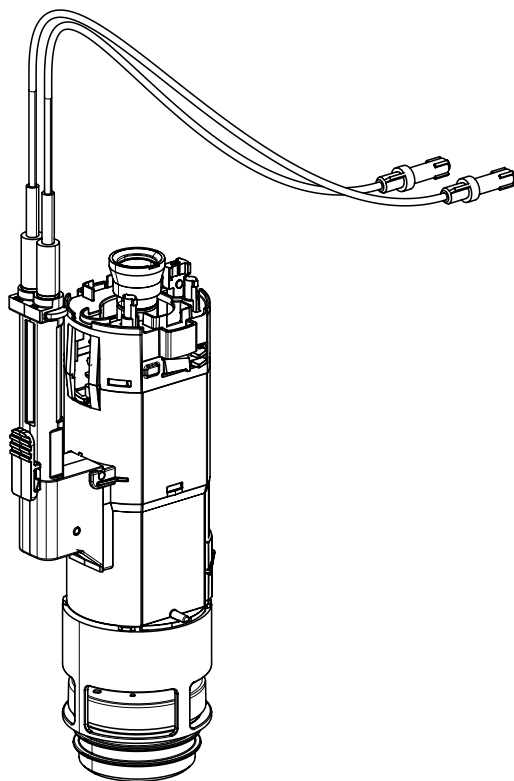

Il est toutefois possible de régler le mécanisme en version NF (3/6 L).
Pour obtenir les réglages, merci de contacter l'assistance technique Nicoll.

Uniquement pour le mécanisme **SIMPLE** câble

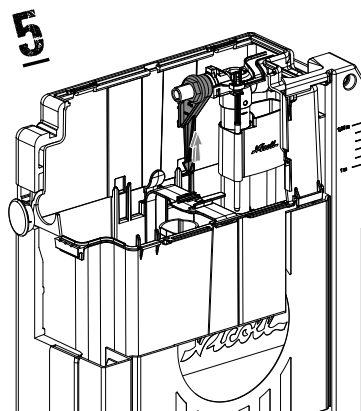
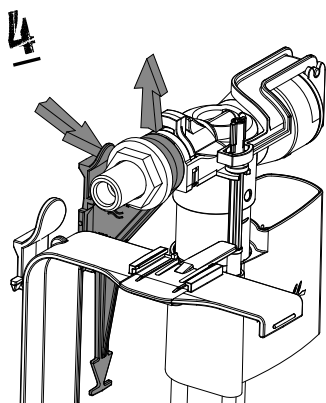
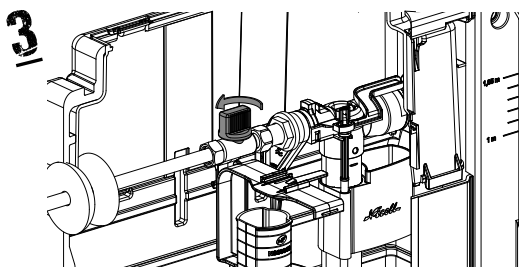
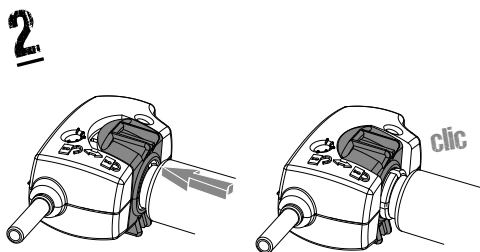
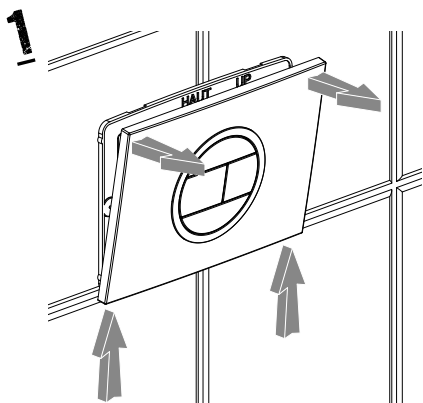

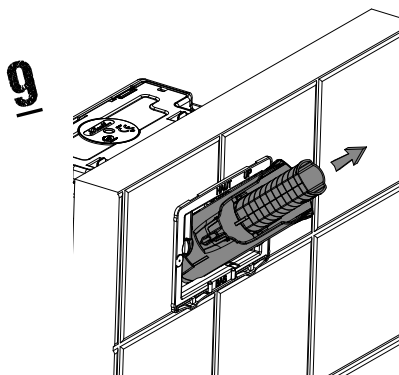
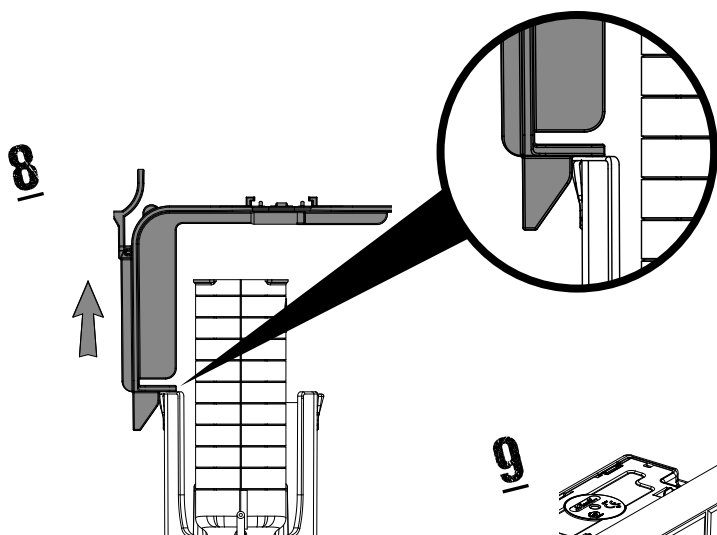
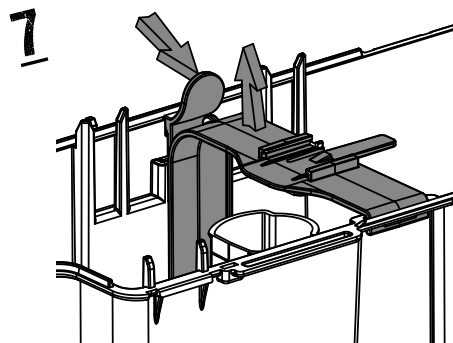
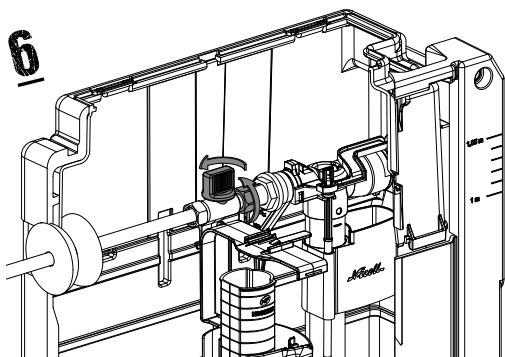

Uniquement pour mécanisme **DOUBLE** câble

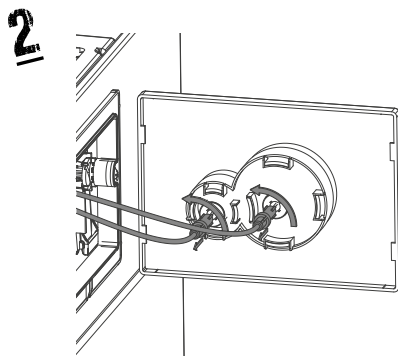
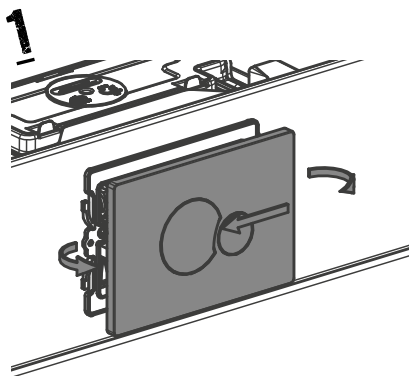

Les étapes **3,4 et 5** sont identiques (cf. p 17)

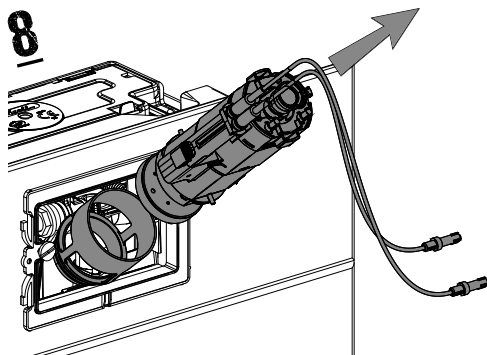
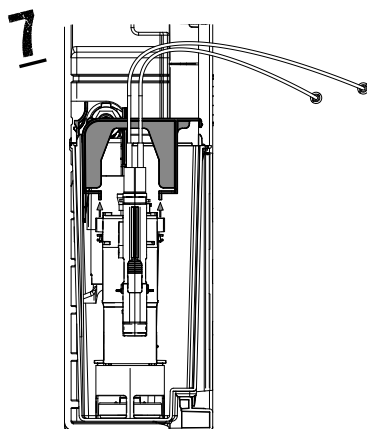
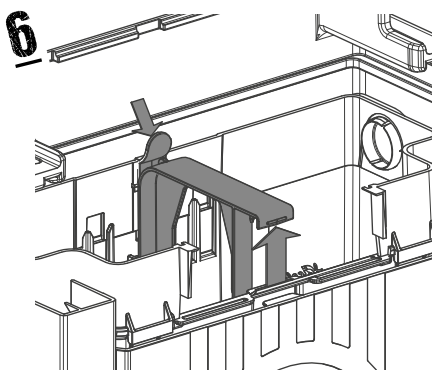

1. Fréquence d'entretien :

En fonction de l'entartrage naturel du réseau et du réservoir avec un entretien annuel conseillé.

2. Étapes :

- a. couper l'arrivée d'eau,
- b. effectuer une grande chasse pour vider le réservoir,
- c. démonter le mécanisme et nettoyer le culot et son joint sans objet abrasif,
- d. remonter l'ensemble du mécanisme,
- e. ouvrir l'arrivée d'eau et verser 50 cl de vinaigre ménager. Mettre 1 L si l'entartrage est important,
- f. augmenter le volume d'eau au-dessus de la ligne d'eau en pressant le sommet de la vis de réglage du robinet flotteur. Relâcher la pression une fois le niveau atteint,

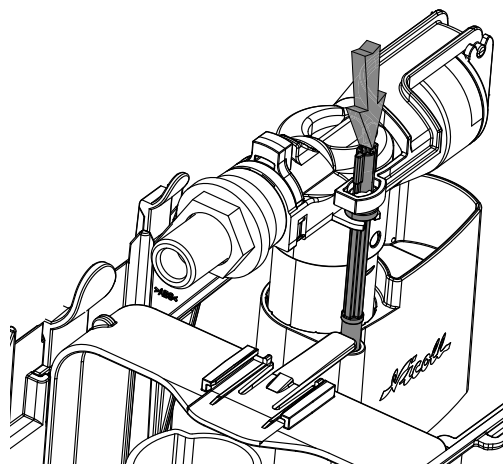

- g. Ne pas tirer la chasse pendant 5 heures.



WALL CONCEALED CISTERN VIRTUO ONE

with a water saving dual flush valve



Installation instructions



Support-frame
WBS1P
WBS1P1N

Nicoll
by aliaxis

SUMMARY

DESCRIPTION	24
SUPPORT FRAME ADJUSTMENT.....	25
INSTALLING THE SUPPORT FRAME	26
INSTALLING THE CONNECTOR	26
ADJUSTING THE FEET AND BRACKETS	26
FIXING THE FRAME & CONNECTING THE DRAIN.....	27
ATTACHING THE PAN	28
CONNECTING THE WATER INLET	29
FITTING THE TILING WITH OPERATING PLATE OR PUSH BUTTON	30
CUTTING THE WATER SUPPLY CONNECTOR AND SOIL AND WASTE SLEEVE	32
INSTALLING THE PAN	33
INSTALLING THE OPERATING PLATE.....	34
INSTALLING THE PUSH BUTTON.....	36
MAINTENANCE OPERATIONS	38
MAINTENANCE PROCEDURE.....	42

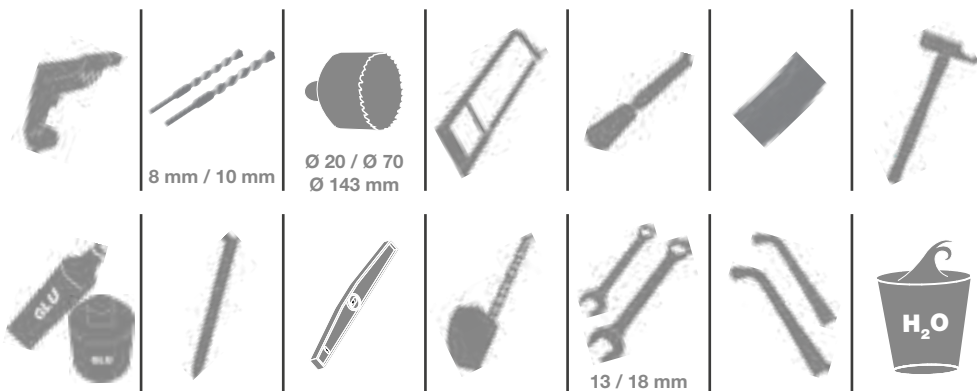

DESCRIPTION

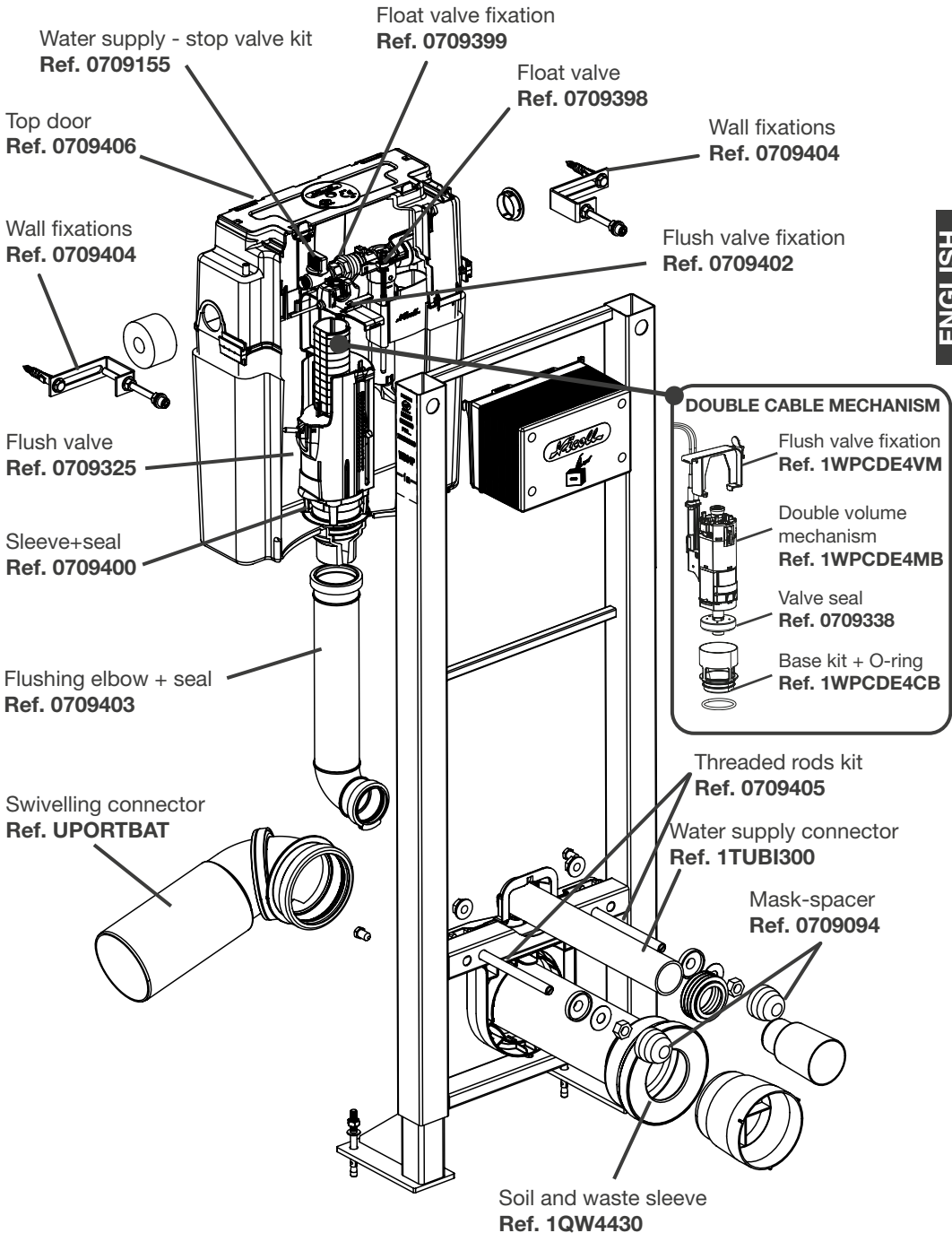

SUPPORT FRAME ADJUSTEMENT

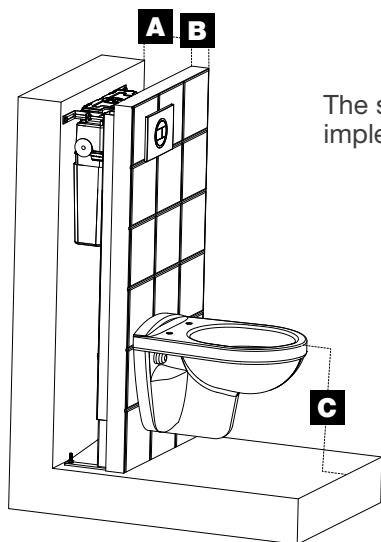

The support frame has to be implemented on a hard wall

- A** = 162 - 197 mm
- B** = 15 - 70 mm (for operating plate)
- B** = 15 - 35 mm (for push button)
- C** = 400 mm (recommended when compatible with your pan) or 450 mm for disabled people

Landmark of 1 m compared to the ground finished to respect to have the bowl with approximately 400 mm of the soil.

D = 1093 - 1332 mm

E = 290 - 525 mm

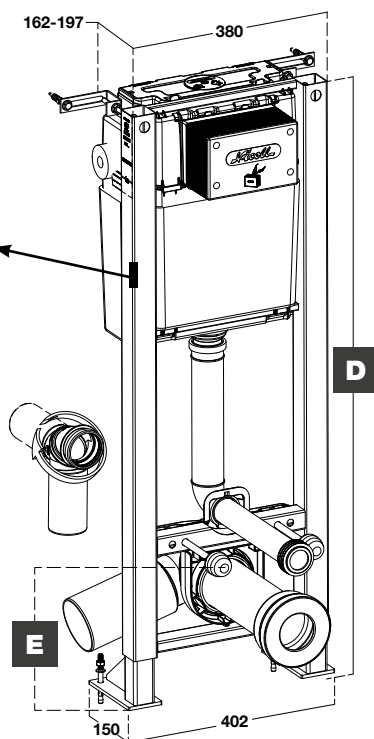

INSTALLING THE CONNECTOR

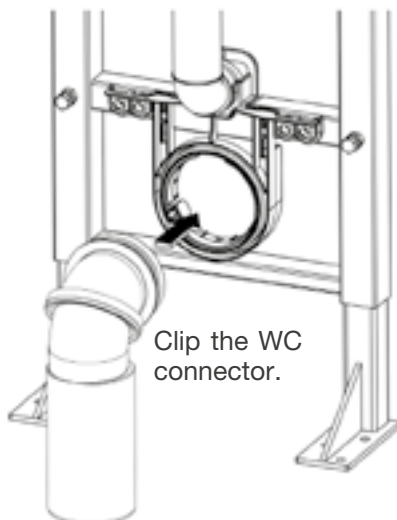

ADJUSTING THE FEET & BRACKETS

After adjusting to the right height, tighten the needle screws ; assemble and adjust the right hand brackets.

1 FEET ADJUSTMENT

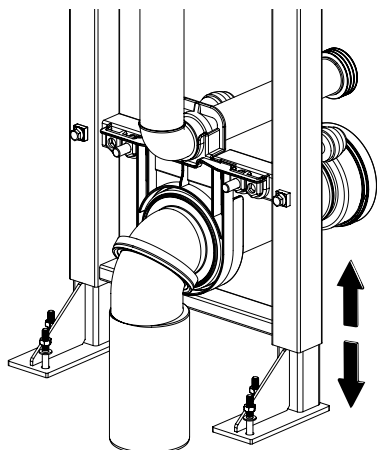

2 BRACKET ADJUSTMENT

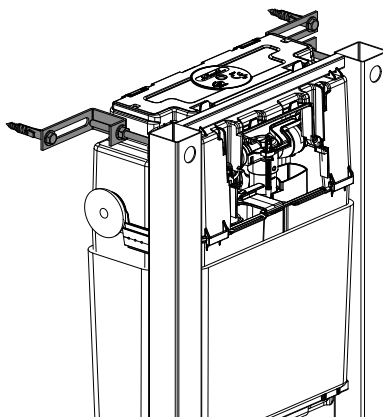

 The pan height position will be final.

INSTALLING THE SUPPORT FRAME

FIXING THE FRAME AND CONNECTING THE

Adjust the connector by cutting the straight section, if necessary.



An adaptor pipe sleeve to fit the piping may be necessary (not supplied).

Install the frame in its final position to validate the adjustments and mark where the holes are to be drilled.
Drill, glue the pipe and permanently fasten the frame.

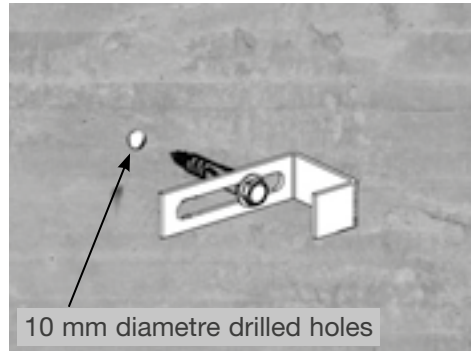
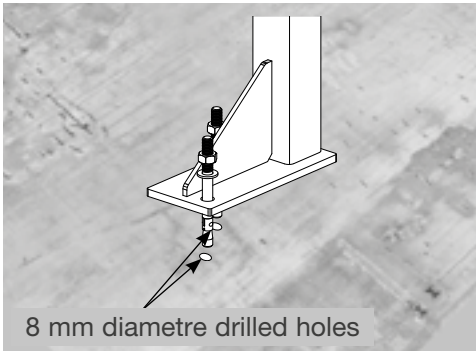
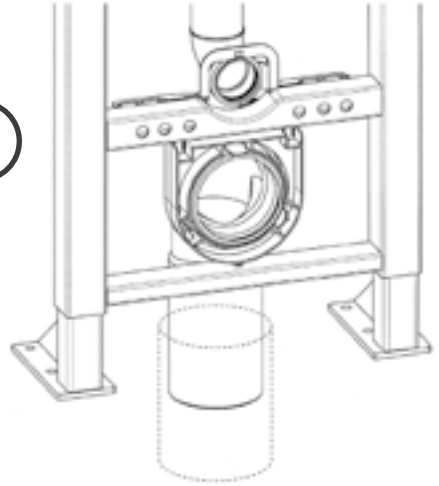

Orientable PVC pipe conector

ATTACHING THE PAN

Select the distance between the fastening rods.

Position the 2 hexagonal flange nuts according to the width between the threaded rods (180 or 230 mm).

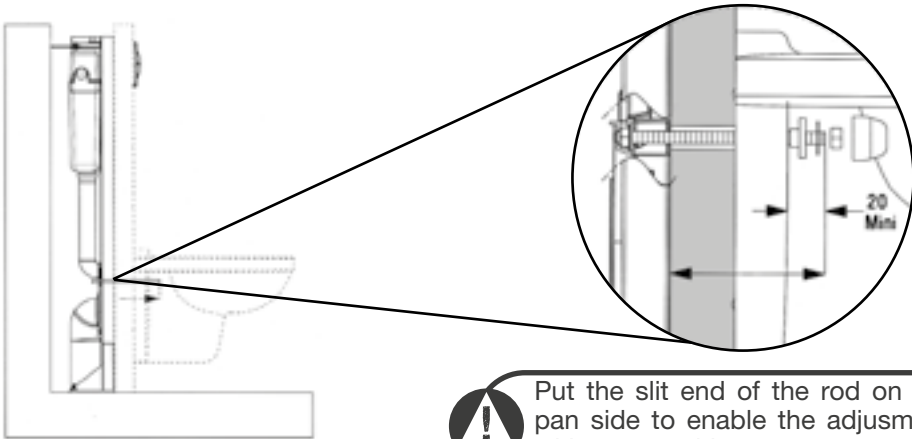
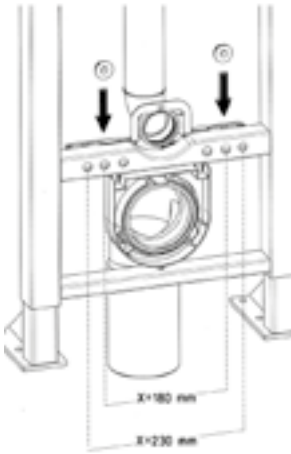

Allow the thickness of the tiling and pan and add 20 mm for adjustment of the fastening rod.

Put the slit end of the rod on the pan side to enable the adjustment with a screwdriver.

CONNECTING THE WATER INLET

It is recommended to connect the water inlet directly to the stop cock. If a flexible tube is used (not supplied), the two fittings at both extremities of the flexible tube must be installed inside the cistern for safety in case of a leak. The water inlet can be installed to the left or to the right of the cistern by breaking the feed hole's protective washer (note: factory mounted for a left side water inlet). Refer to the maintenance operations to see how to change the float valve for a right side water inlet installation.

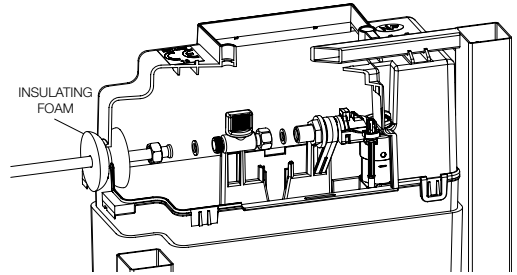

it will also reverse the flush mechanism.

Bleeding the water feeding pipe:
Remove the float valve by pulling on the tab and then lifting the float valve and its support.

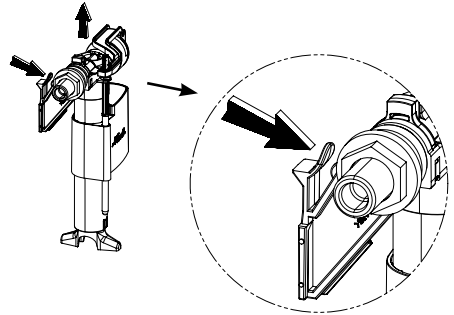

Bleed to evacuate impurities. Make sure the water inlet is sealed correctly to prevent leaking and reinstall the float valve.

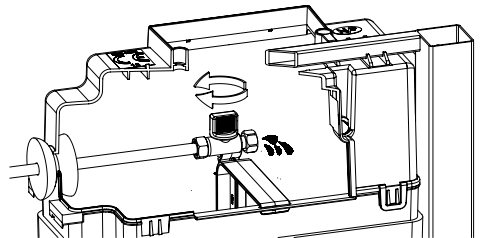

It is recommended to test the complete assembly (with the pan and connectors) to make sure it is leak-proof before installing the tiling (replace the paneling between the frame and the pan by wedges). Carry out a few complete toilet cistern filling and flushing cycles.

FITTING THE TILING

1A INSTALLATION WITH OPERATING PLATE

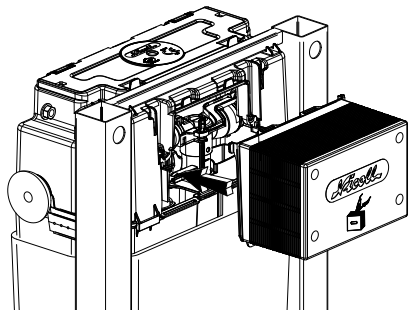

Install the polystyrene template.

 Place tiling flush with template.

The tiling thickness must NOT exceed 70 mm.

If implementation in hollow wall, don't forget to add shim.

1B INSTALLATION WITH PUSH BUTTON FIREWALL CONTROL BUTTON REF.: WBCCFB / WBCCFC / WBCCFS

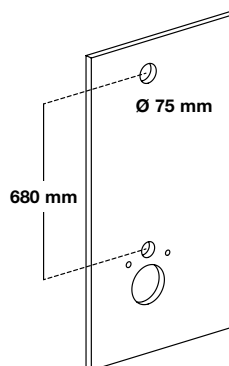
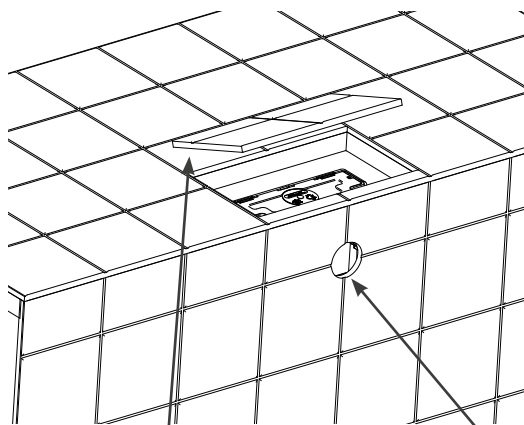

 Don't forget to plan an access hatch in case of any maintenance operations.

Plan a 75 mm diameter hole to install the push button.

The tiling thickness must NOT exceed 62 mm or 117 mm if you are using the extension.

If implementation in hollow wall, don't forget to add shim.

INSTALLING THE SUPPORT FRAME

1C INSTALLATION WITH PUSH BUTTON 403L / 404L / 405L

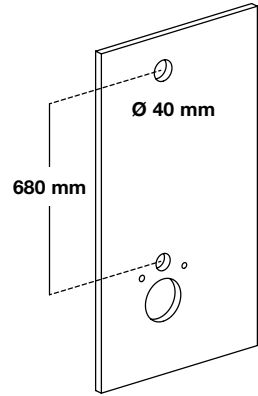
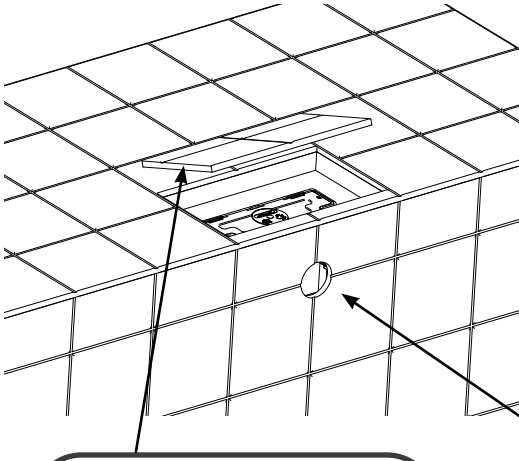

! Don't forget to plan an access hatch in case of any maintenance operations.

Plan a 40 mm diameter hole to install the push button.

The tiling thickness must NOT exceed 35 mm or 90 mm if you are using the extension.

If implementation in hollow wall, don't forget to add shim.

2 PROTECTION OF THE RODS & PIPES

Install the threaded rod protections (protective ringed tubes) and plugs.

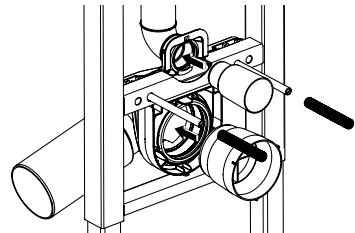

This system offers you a large number of personalized finish choices and the tiling structure can be completed with many solutions:

- with square plaster panels, bricks, etc.
- with marine fiberboard panels
- with 2 superposed waterproof BA13 plates
- with 1 waterproof BA18 plate

The tiling is installed from page 29 to 31 of the installation guide.

AFTER TILING:

To facilitate the operations described pages 31 and 32 apply some grease to the seals of each fitting or tube.

CUTTING THE WATER SUPPLY CONNECTOR AND SOIL AND WASTE SLEEVE

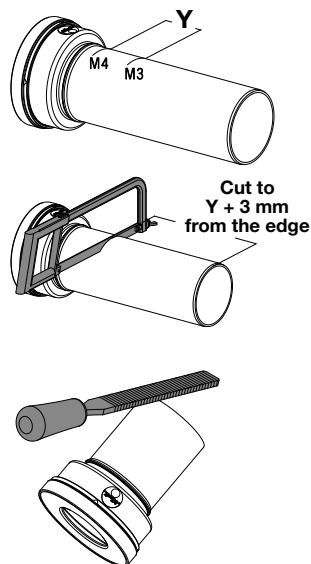
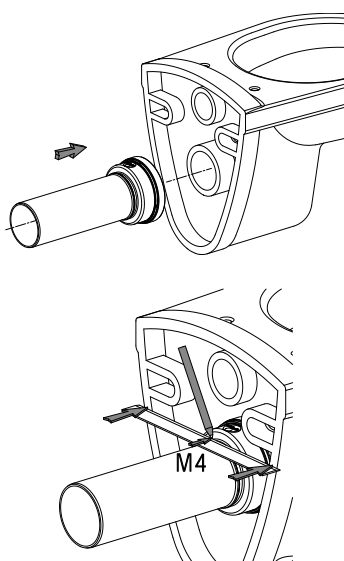
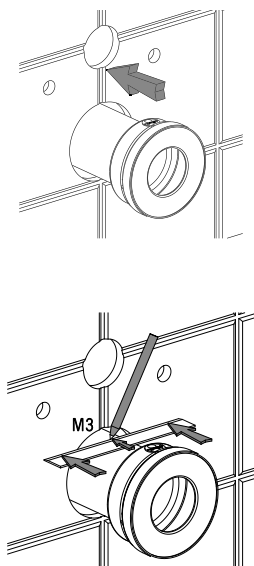
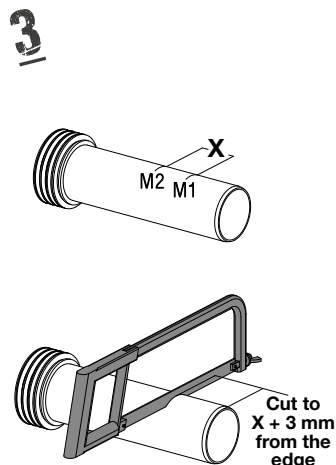
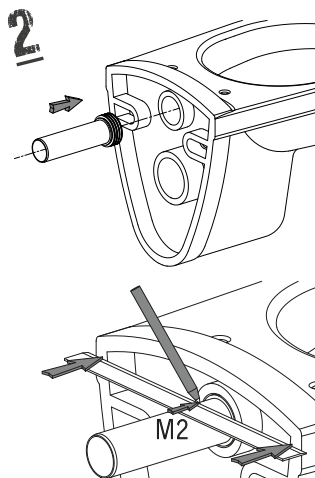
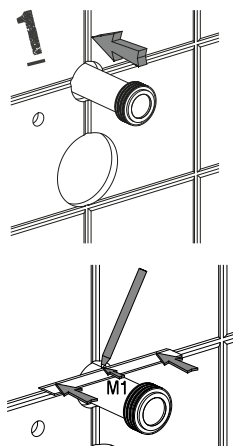

INSTALLING THE PAN

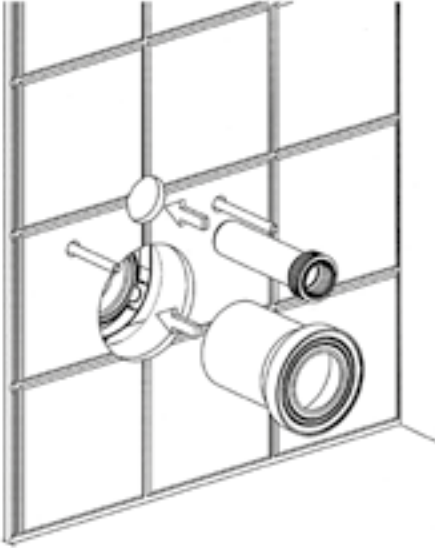

Push the tube and sleeve onto the frame through the tiling.

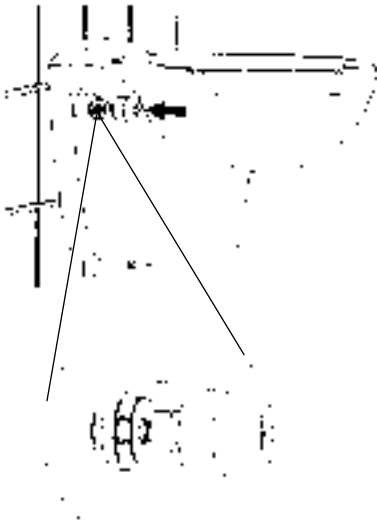

Install the pan on the fastening rods.



mounting the bowl on a double-walled hollow partition requires the installation of shims or a reinforcement plate.

INSTALLING THE OPERATING PLATE

A CUTTING THE TEMPLATE

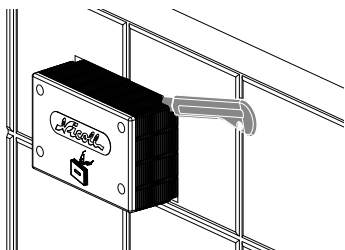

Cut the template to install the support frame for the operating plate.

B1 INSTALLING THE CONTROLE PLATE WITH SIMPLE CABLE



Remove the screws from the frame, fettle the screw head and the frame. Insert the screws slanted as shown on the drawing.

Tighten down to the last threads.

B2 INSTALLING THE CONTROLE PLATE WITH DOUBLE CABLE

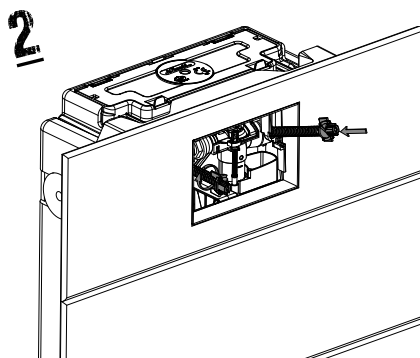
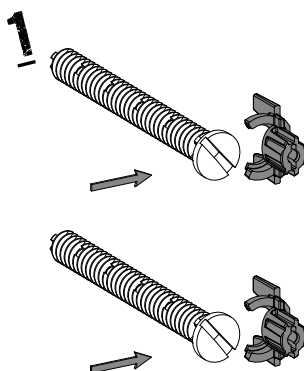

INSTALLING THE SUPPORT FRAME

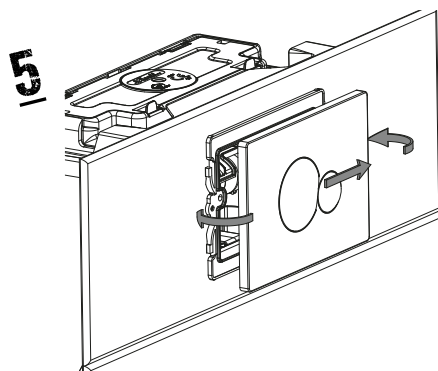
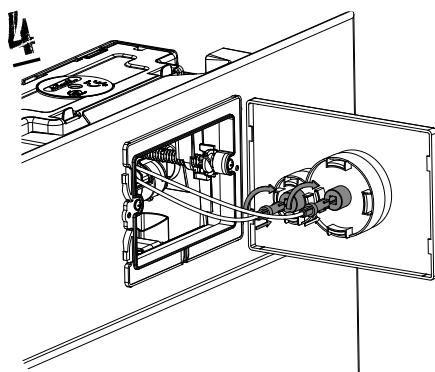
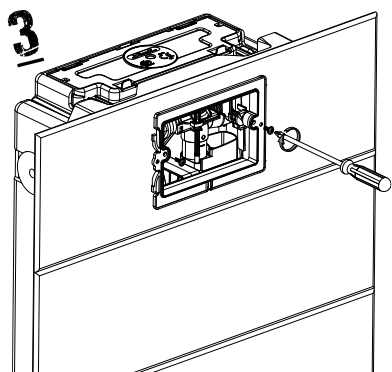

C INSTALLING WITH OPERATING PLAQUE

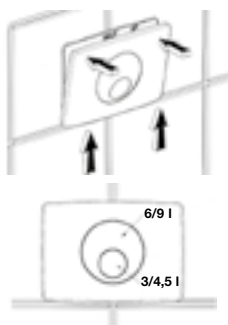
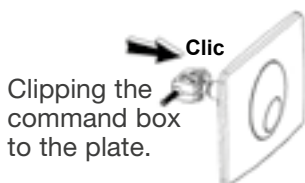

Installing the control plate

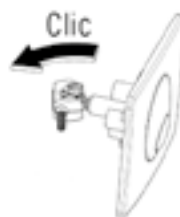

Unlocking the command box and unclipping the plate.

INSTALLING THE PUSH BUTTON

Only for the single cable mechanism

1 INSTALL THE BUTTON WITH THE NUT

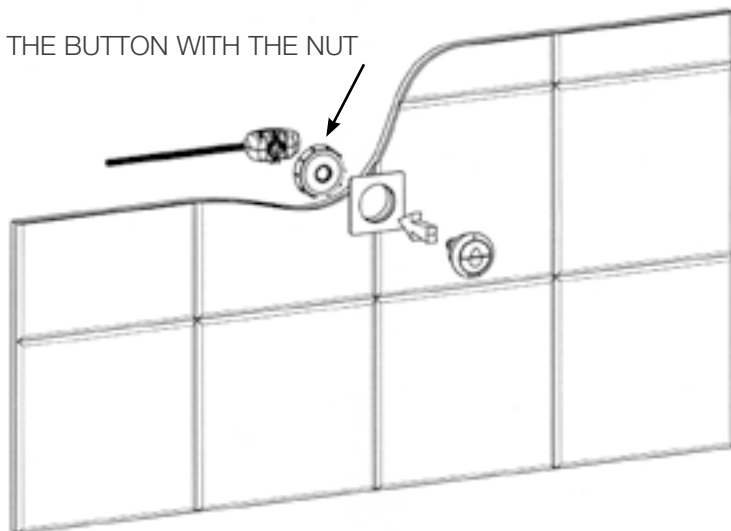

For details, refer to the installation instructions supplied with the control but-

2 CONNECTION OF THE PUSH BUTTON TO THE MECHANISM

Clip onto the push button.



Lock the clip to the button.



REFERENCES WBS1PECO / WBS1PECO2

WBS1PECO

The WBS1PECO version is supplied with a factory-set single cable mechanism with flush volumes of 3 and 4.5L (non-NF configuration).

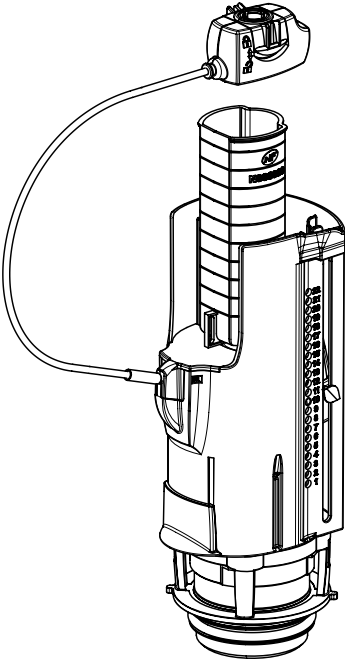

WBS1PECO2

The WBS1PECO2 version is supplied with a factory-set dual cable mechanism with flush volumes of 3 and 4.5L (non-NF configuration).

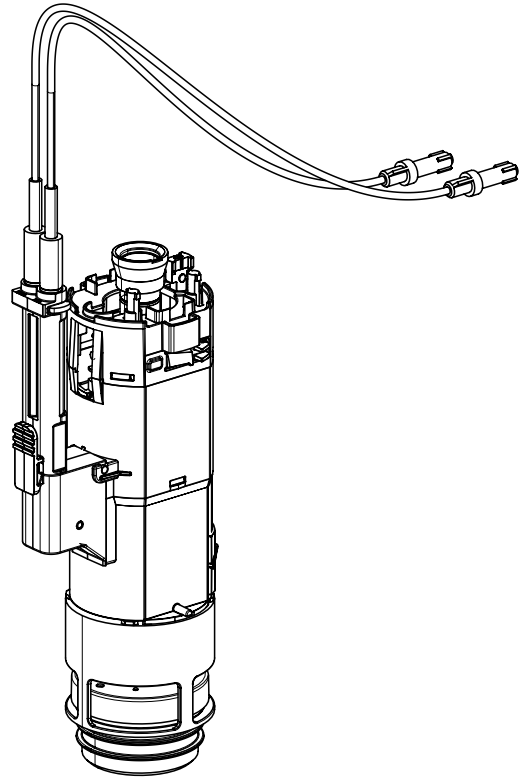

It is possible to adjust the mechanism in NF version (3/6 L).
For settings, please contact Nicoll Technical Support.

Only for the **SINGLE** cable mechanism

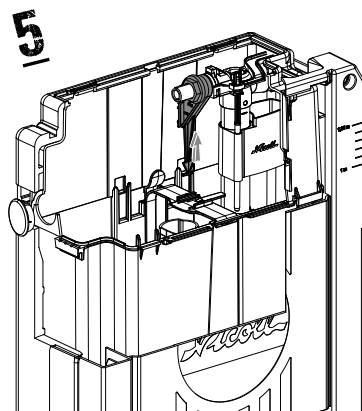
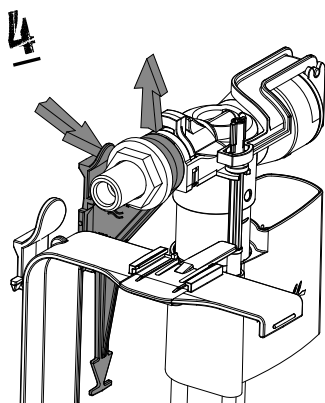
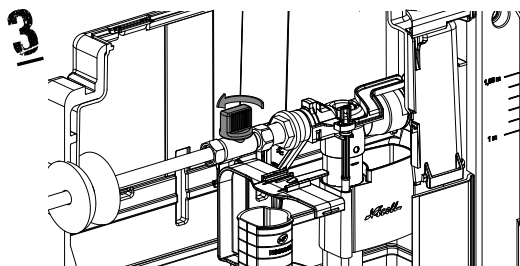
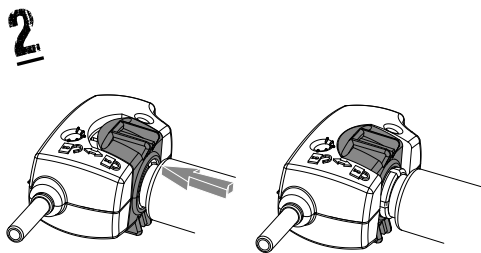
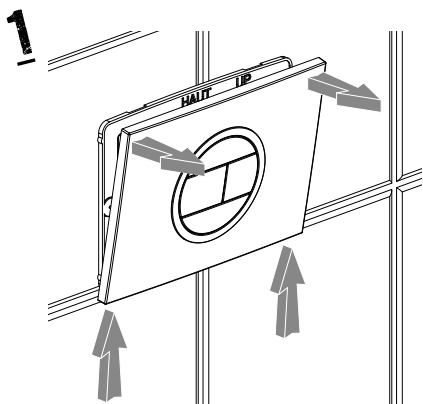

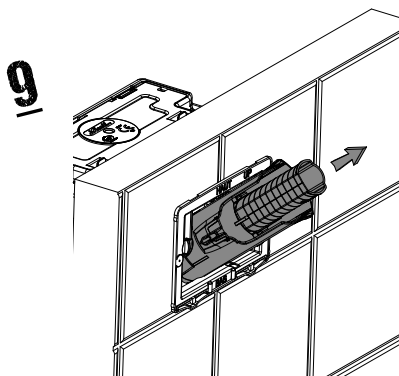
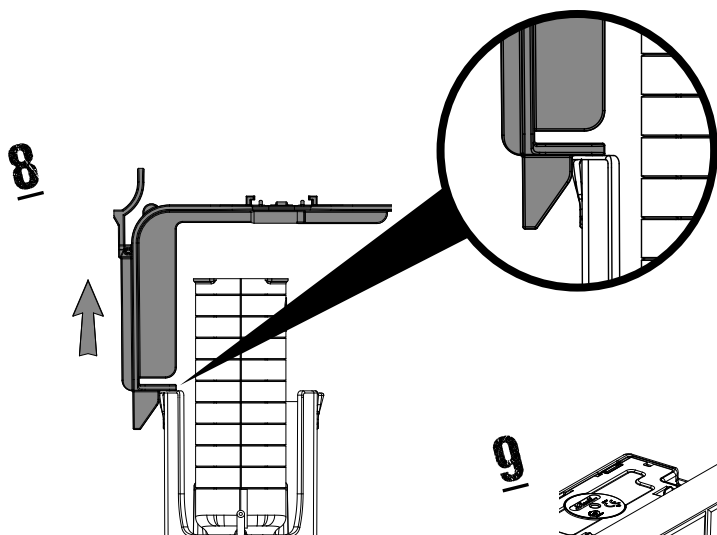
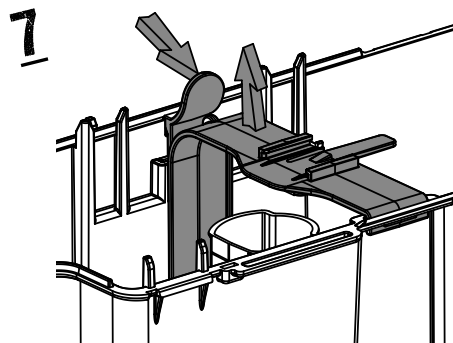
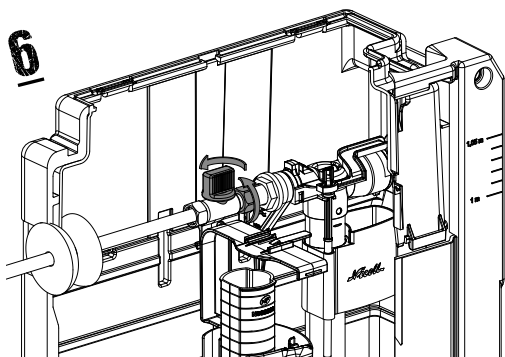

Only for the **DOUBLE** cable mechanism

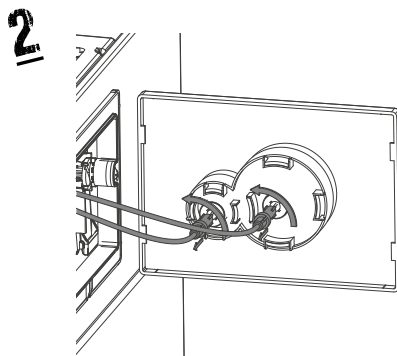
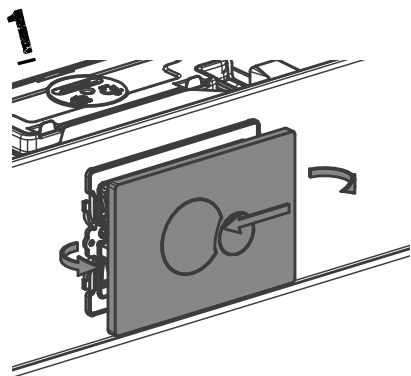

Steps 3, 4 and 5 are identical (see p 17)

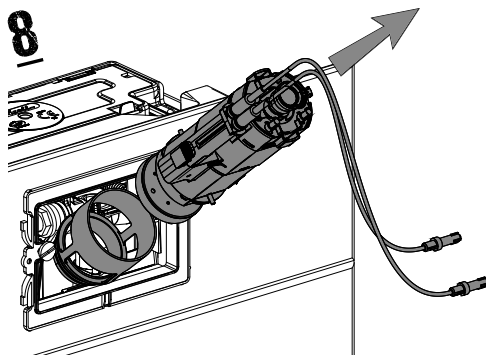
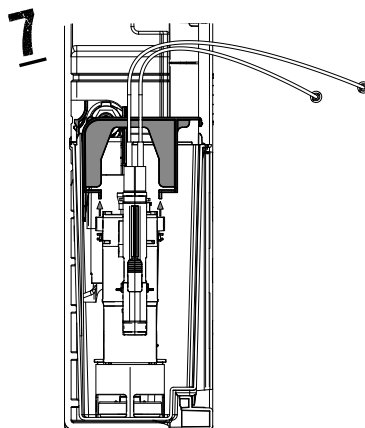
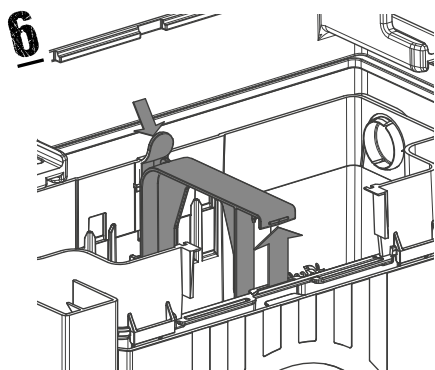

MAINTENANCE PROCEDURES

1. Maintenance frequency:

depending on natural limescale with a recommended yearly maintenance.

2. Steps:

- a. turn off the water supply,
- b. empty the tank by flushing,
- c. disassemble the flush valve and clean up the sleeve and the seal without an abrasive object,
- d. reassemble the full flush valve,
- e. open the water supply and add 50 clm of white vinegar. In case of massive scaling, add 1L.,
- f. increase the water volume over the water surface pushing the float valve adjustment screw top,

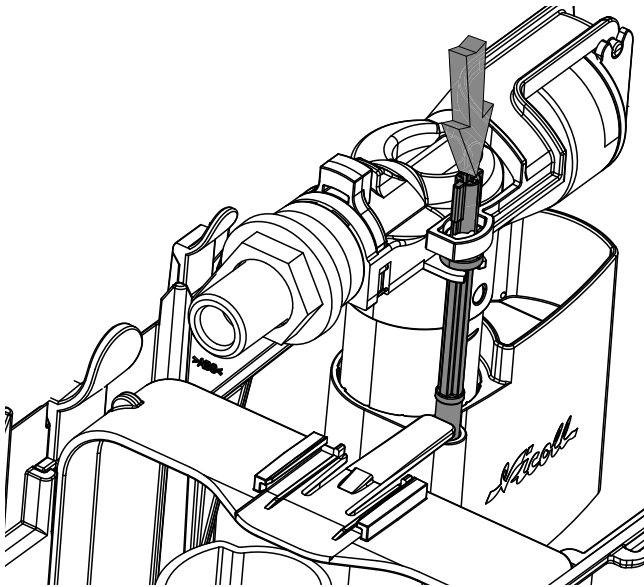

g. do not flush during 5 hours.



BÂTI-SUPPORT MURAL VIRTUO MIX



Notice de pose

Bâti-support
WBSA2R
WBSA2R2C



Nicoll

by aliaxis

SOMMAIRE // SUMMARY

DESCRIPTION & PIÈCES DÉTACHÉES // Description & spare parts	44
TYPE DE POSE/RÉGLAGES // Type of installation/adjustment	45
MISE EN ŒUVRE // Installation	46
FIXATIONS SOL // Floor fixation	46
RÉGLAGE EN HAUTEUR // Height Adjustment.....	47
FIXATIONS MUR - RÉGLAGES APLOMB // Wall fixations & depth setting.....	48
RACCORDEMENT ÉVACUATION // Soil & waste connection.....	49
MONTAGE DU RÉSERVOIR // Cistern assembly	52
ALIMENTATION À GAUCHE OU À DROITE // Water supply by the right or the left	53
PRÉPARATION/MONTAGE CUVETTE & HABILLAGE // Bowl preparation/assembly and covering.....	54
HABILLAGE ET REVÊTEMENT // Covering	56
MONTAGE MANCHONS D'ALIMENTATION ET D'ÉVACUATION // Assembly of water supply/soil & waste connectors.....	57
PURGE ET RACCORDEMENT DU ROBINET FLOTTEUR // Clean-up & float valve connection.....	58
MONTAGE DE LA PLAQUE DE COMMANDE // Control plate assembly.....	59
ESSAIS DE FONCTIONNEMENT // Function check	60
MAINTENANCE // Maintenance	61
PROCÉDURE D'ENTRETIEN // Maintenance procedure	63

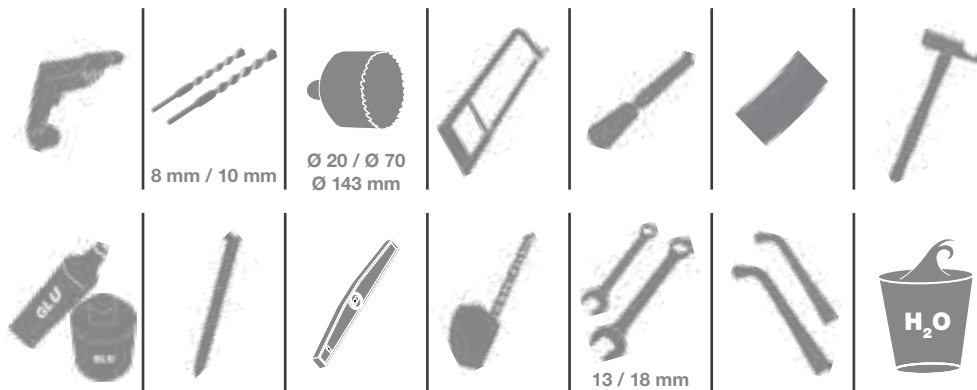

DESCRIPTIONS & PIÈCES DÉTACHÉES // DESCRIPTION & SPARE PARTS

Kit alim-robotet arrêt // Water supply- stop valve kit

Réf. 0709155

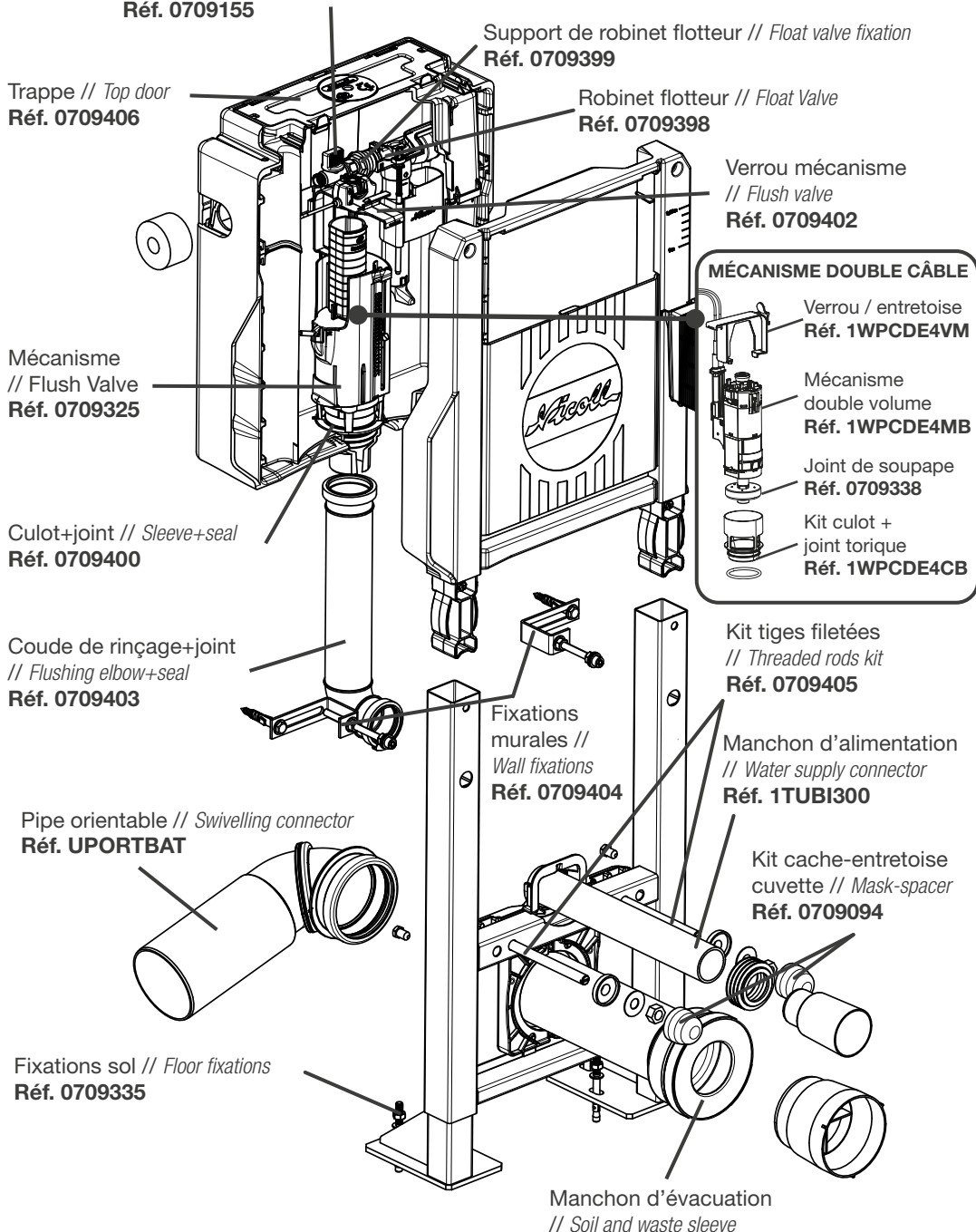

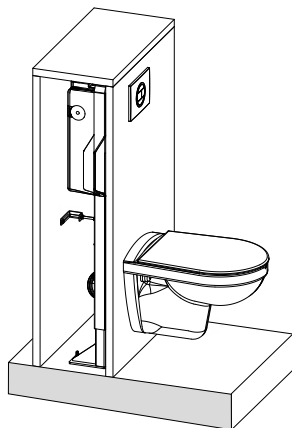

Autoportant sur sol porteur

Self-supporting on loadbearing floor

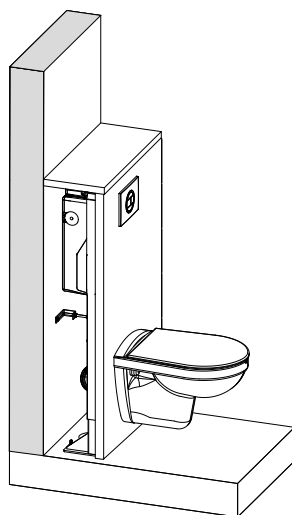

Mural sur mur porteur

Wall hung on loadbearing wall

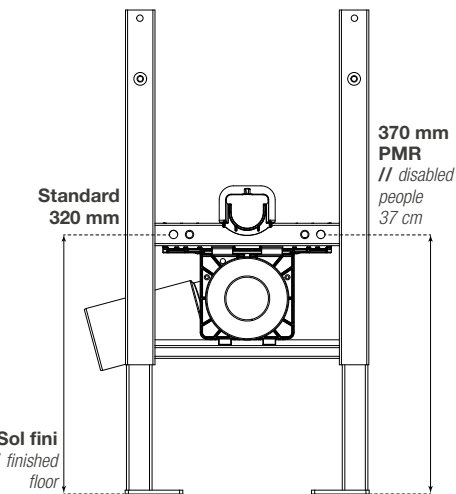
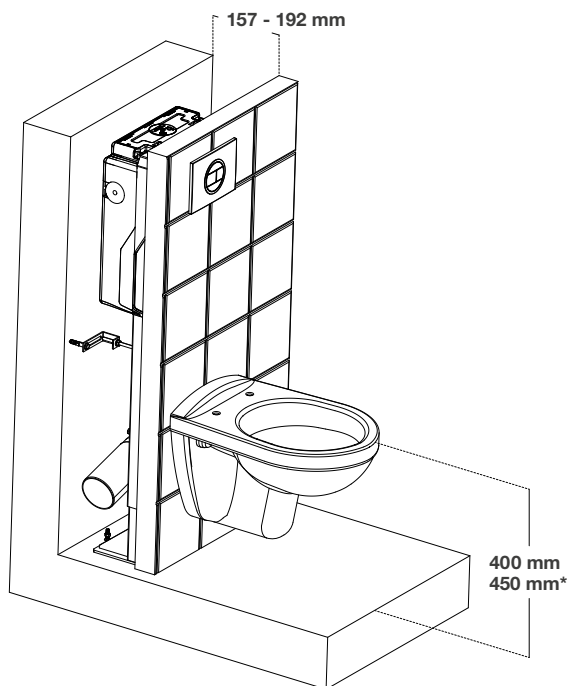

* 400 mm (recommandé si compatible avec votre cuvette)
 ou 450 mm pour personnes à mobilité réduite
*400 mm (recommended for standard installation)
 or 450 mm (for disabled people)*

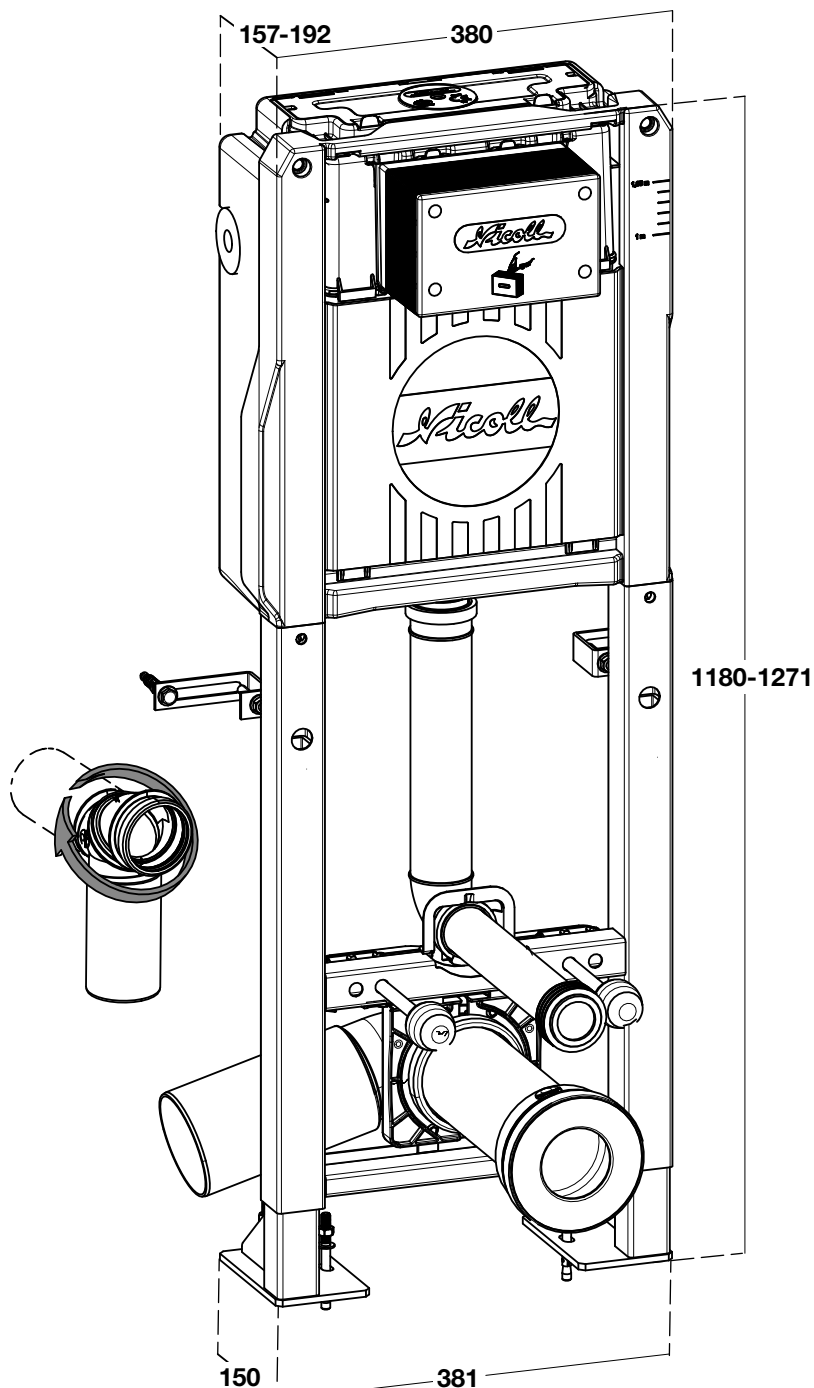

FIXATIONS SOL // FLOOR FIXATIONS

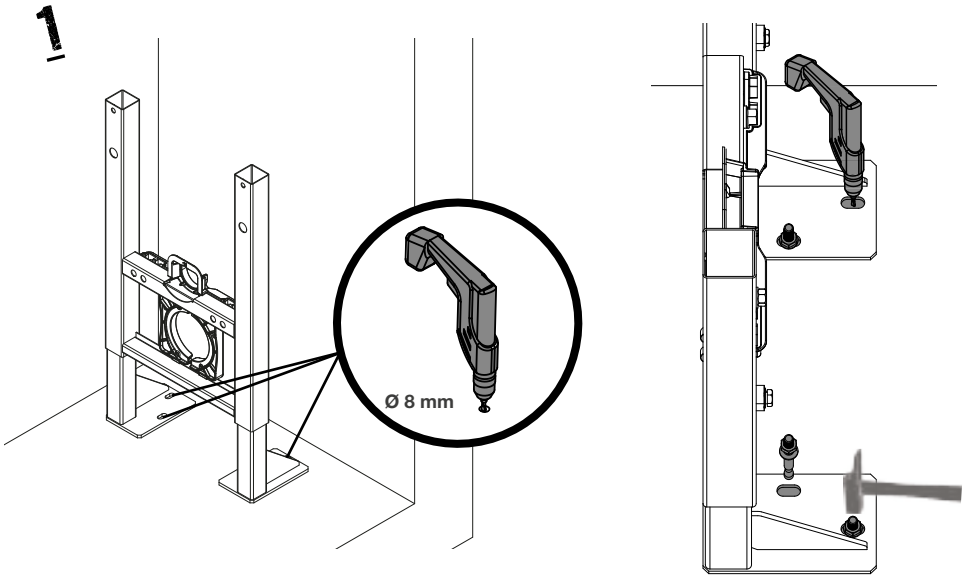

Pré-serrage // Pre-clamping

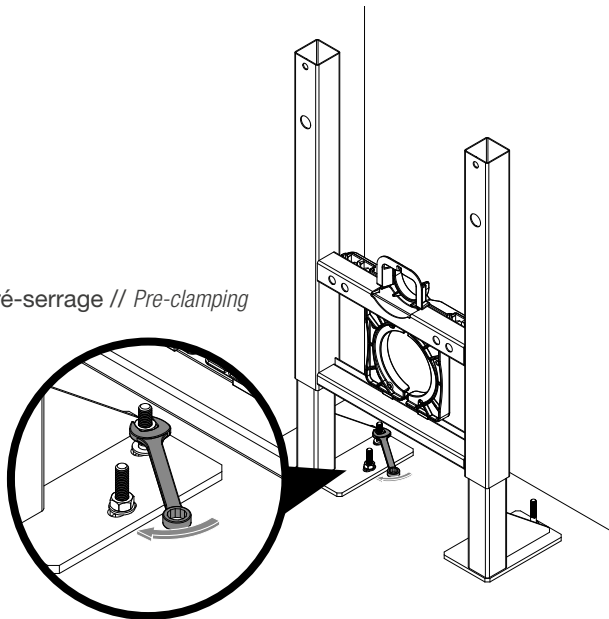

RÉGLAGE EN HAUTEUR // HEIGHT ADJUSTMENT

1

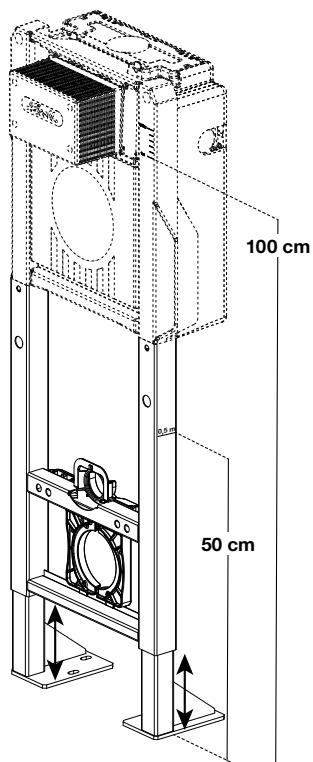

2

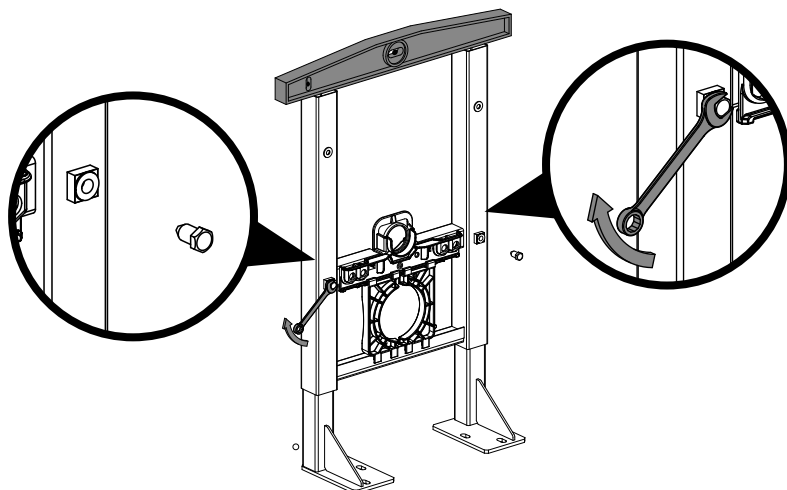

FIXATIONS MUR - RÉGLAGES APLOMB

// WALL FIXATIONS AND DEPTH SETTING

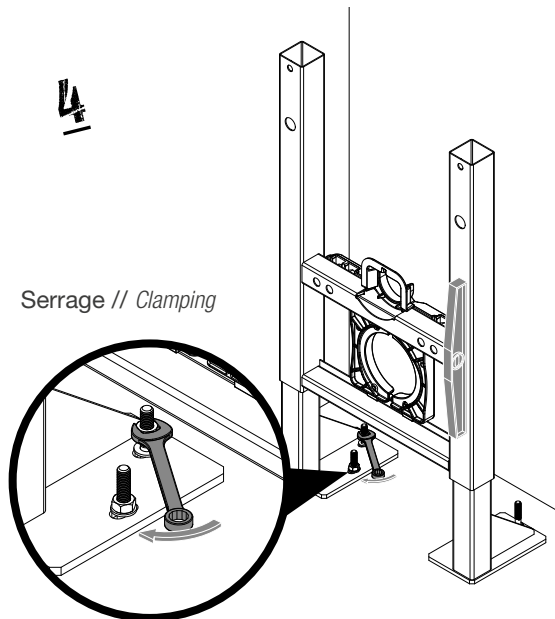
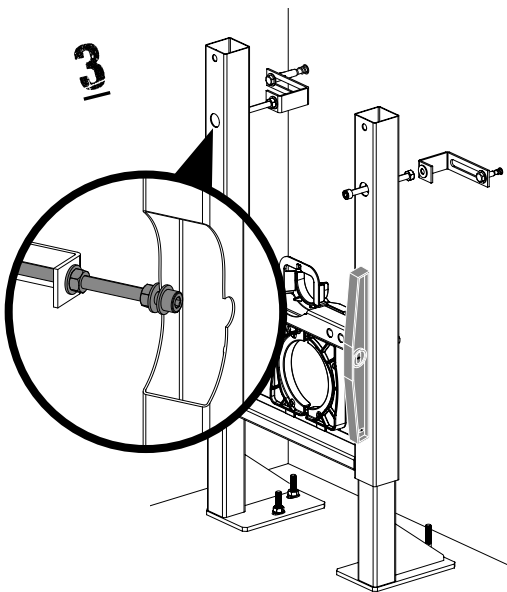
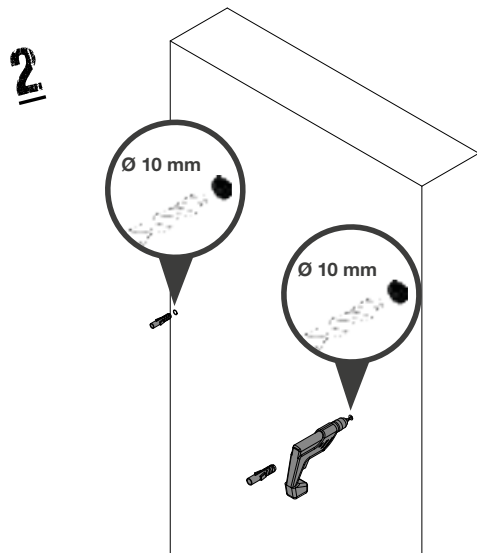
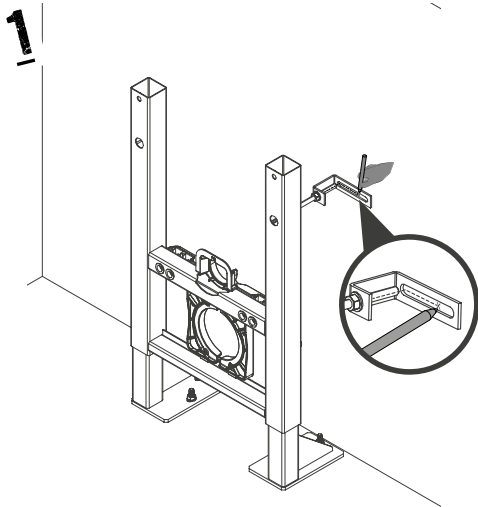

RACCORDEMENT ÉVACUATION // SOIL & WASTE CONNECTION

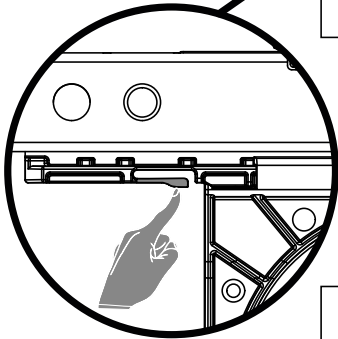
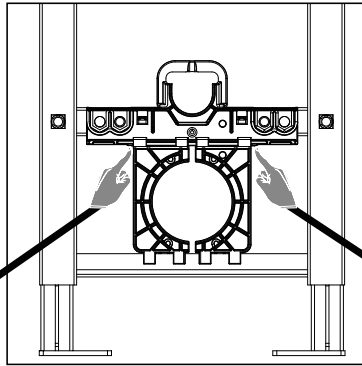

**Appuyer
sur la butée
pour déverrouiller
le collier**

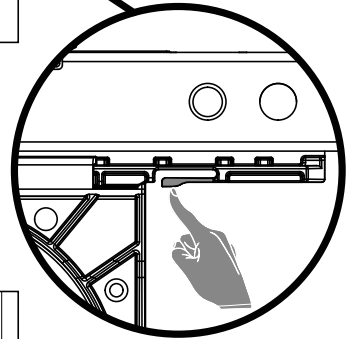

*Press the stop to
unlock the collar*

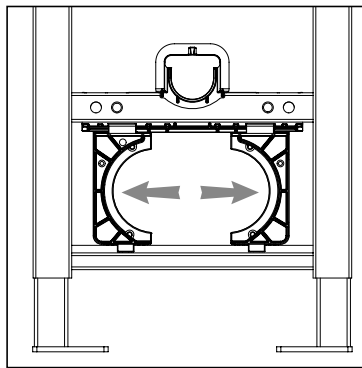

1

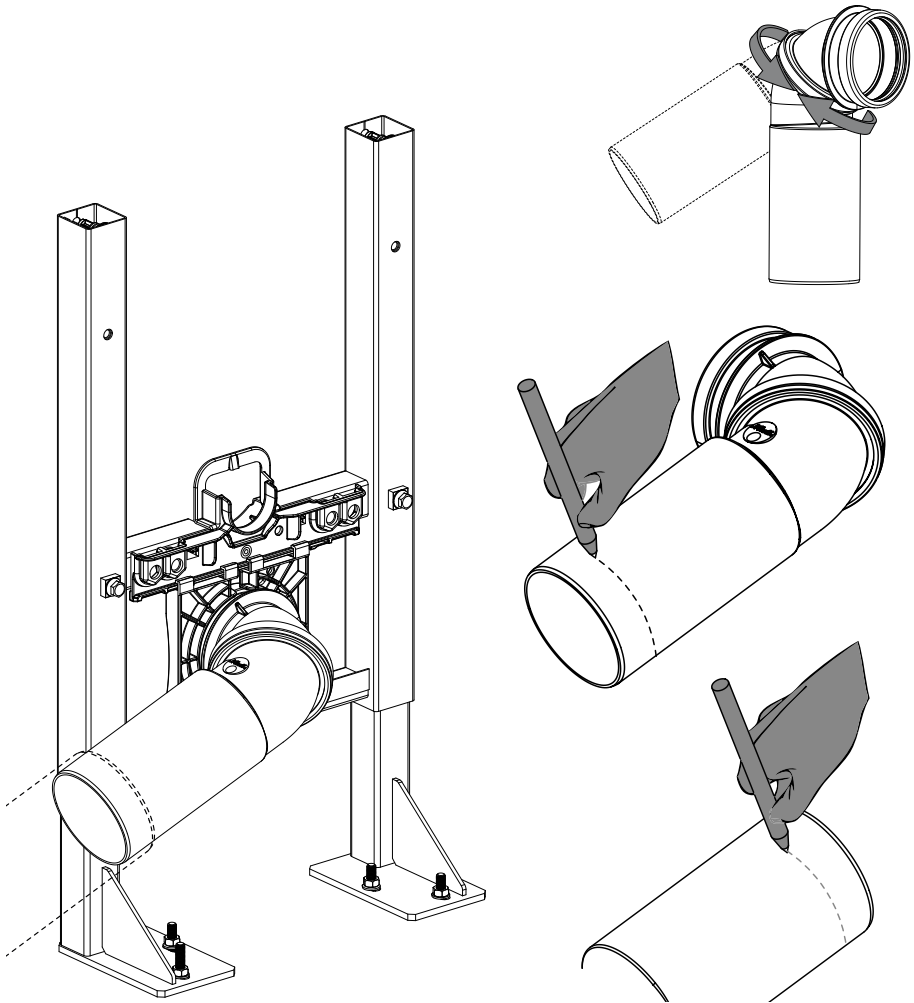

2

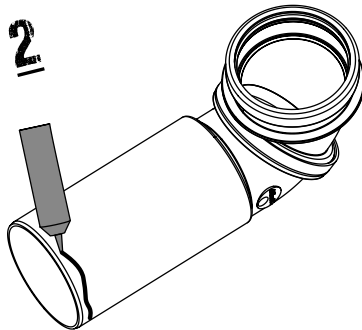

3

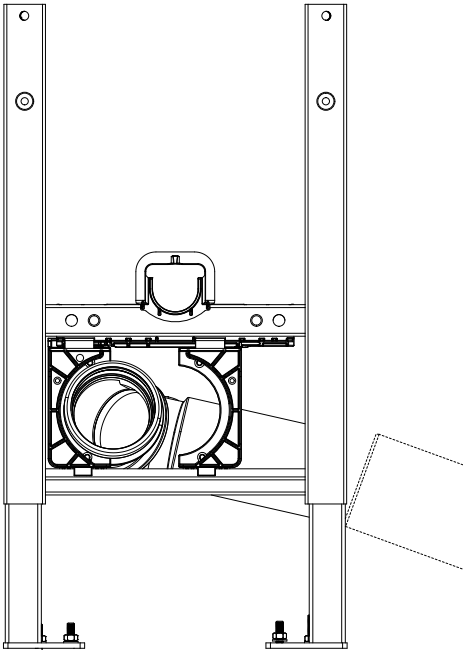

4

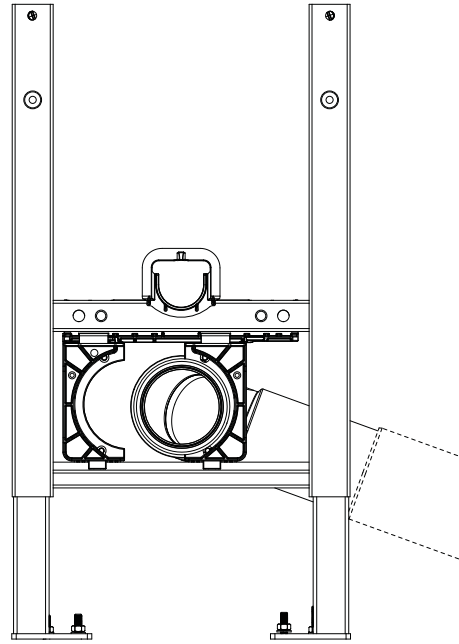

5

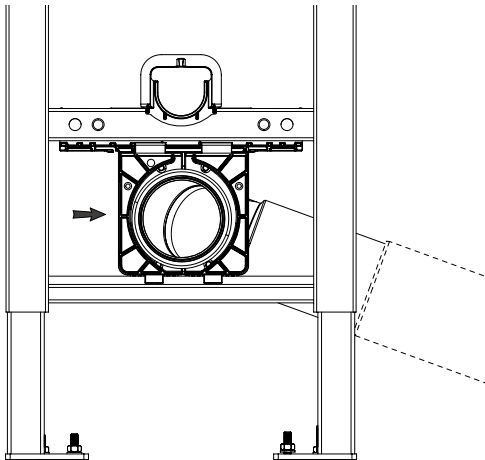

6

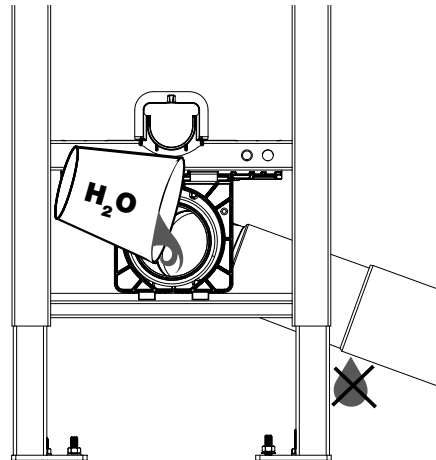

MONTAGE DU RÉSERVOIR // CISTERN ASSEMBLY

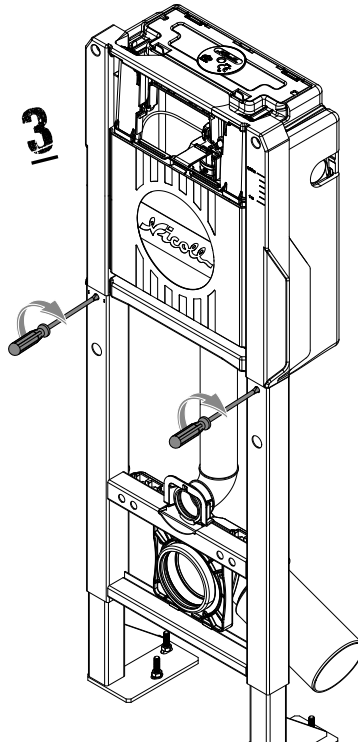
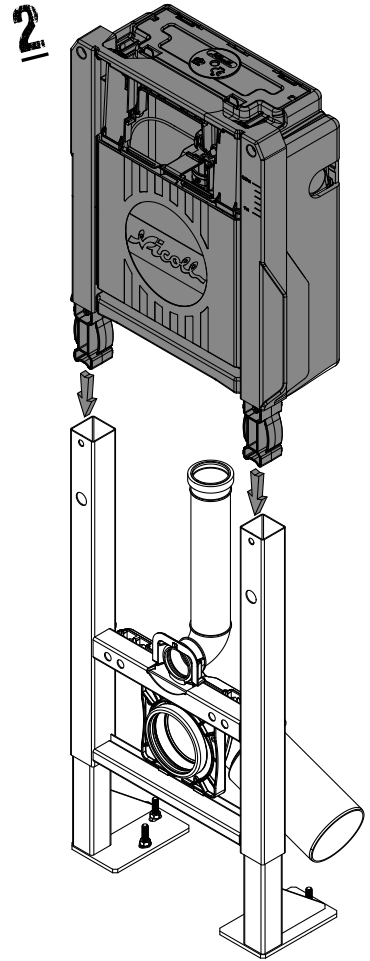
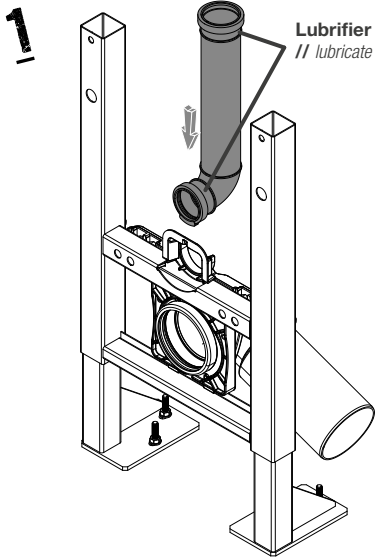

ALIMENTATION À GAUCHE OU À DROITE

// WATER SUPPLY BY THE RIGHT OR THE LEFT

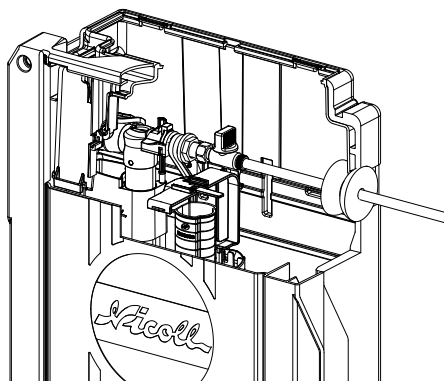
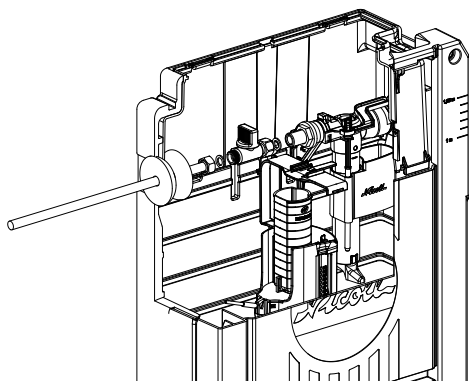

**Pour changer le sens
d'alimentation, démonter
le robinet flotteur.**

*To change the water supply side,
disassemble the float valve.*

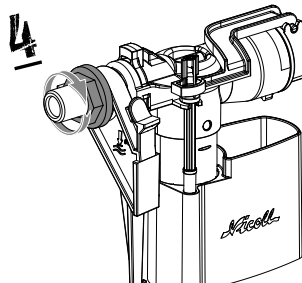
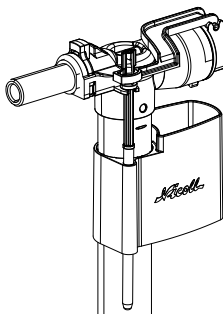
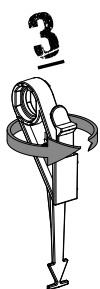
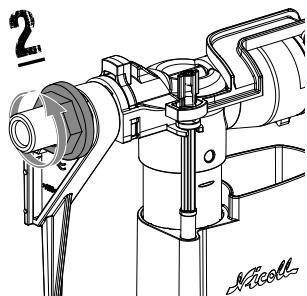
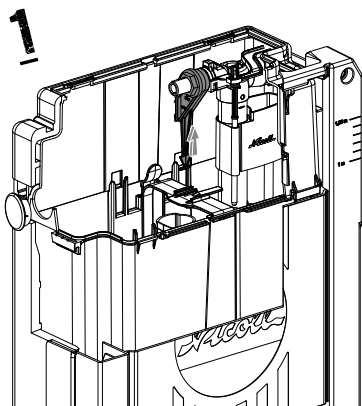

PRÉPARATION/MONTAGE CUVETTE & HABILLAGE

// BOWL PREPARATION/ASSEMBLY AND COVERING

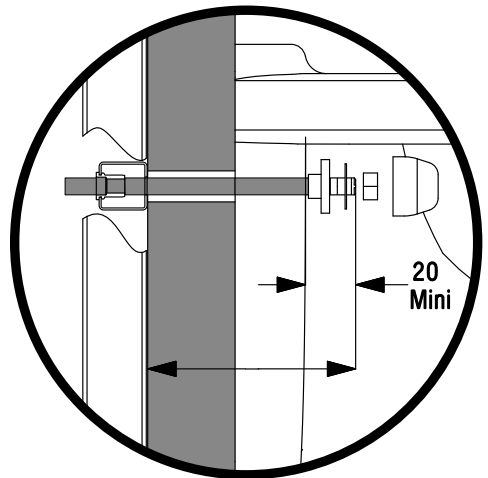
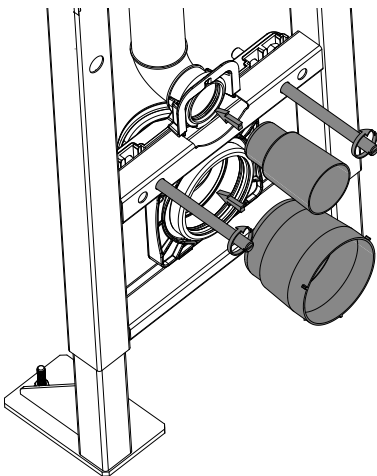
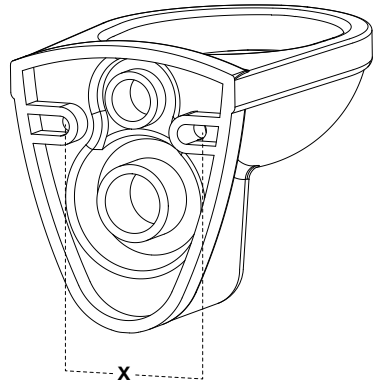
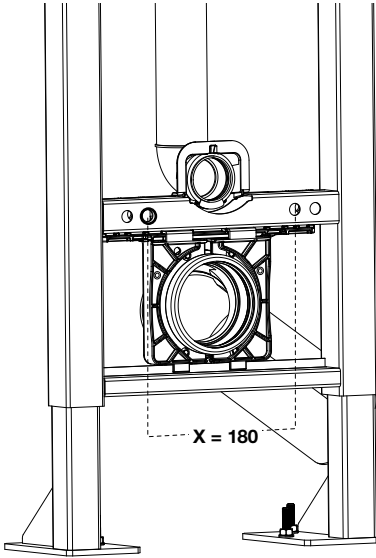

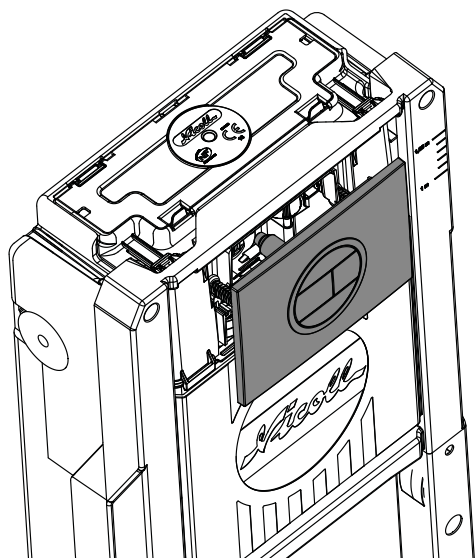
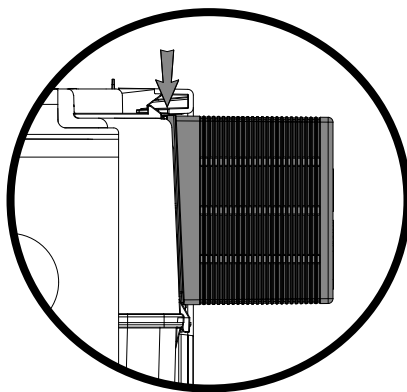
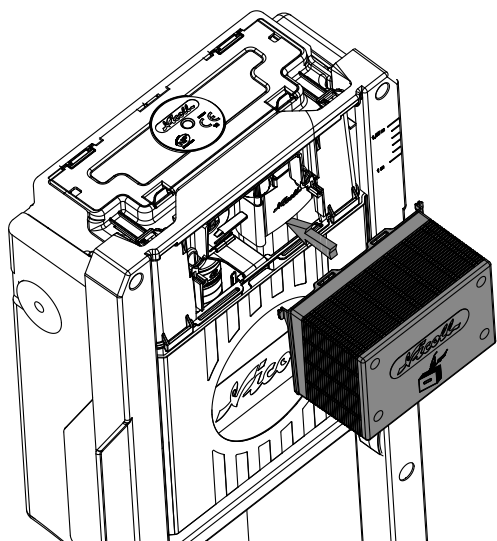

HABILLAGE ET REVÊTEMENT // COVERING

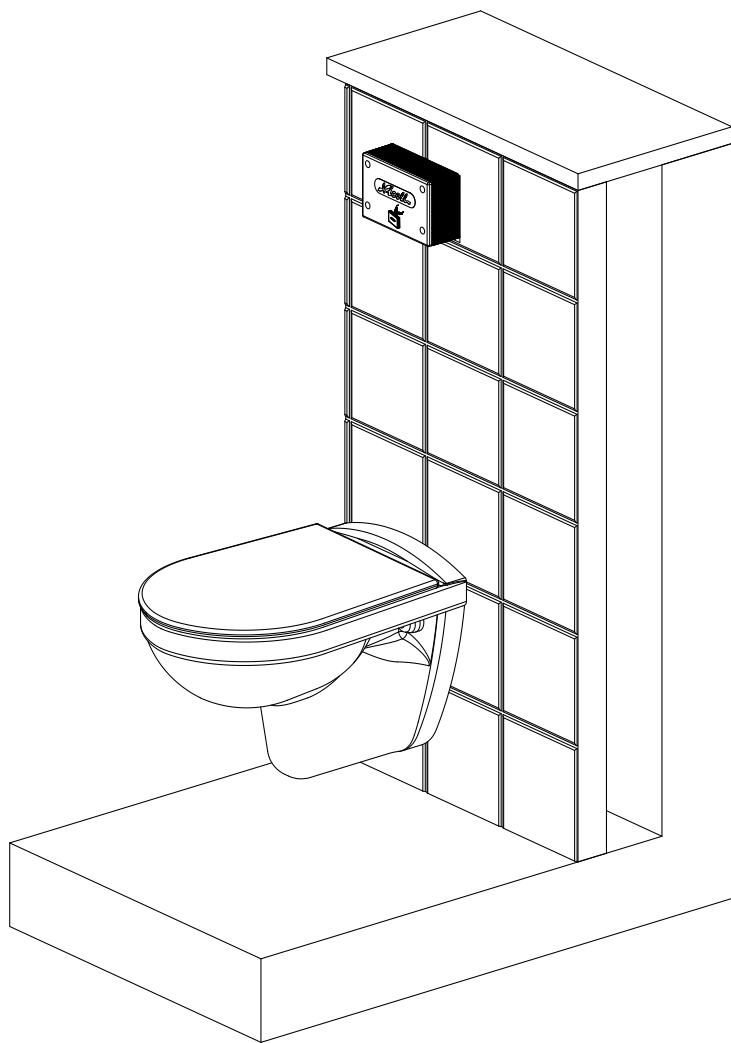

MONTAGE MANCHONS D'ALIMENTATION & D'ÉVACUATION // ASSEMBLY OF WATER SUPPLY/SOIL & WASTE CONNECTORS

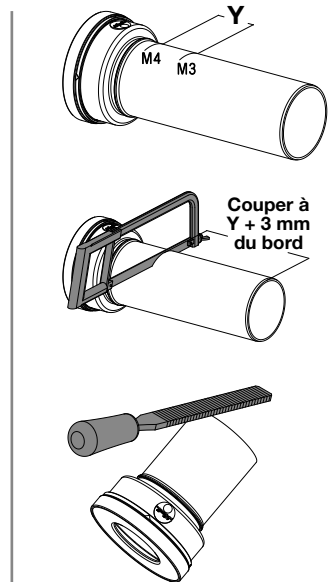
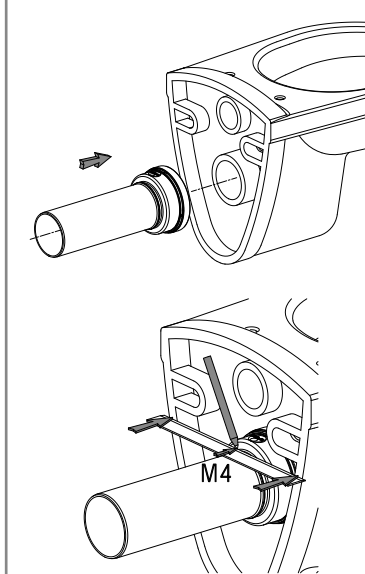
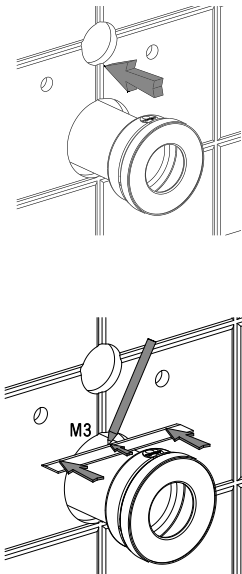
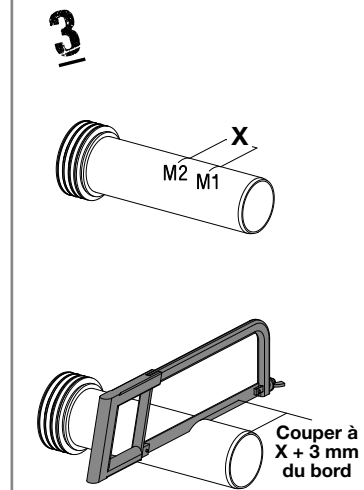
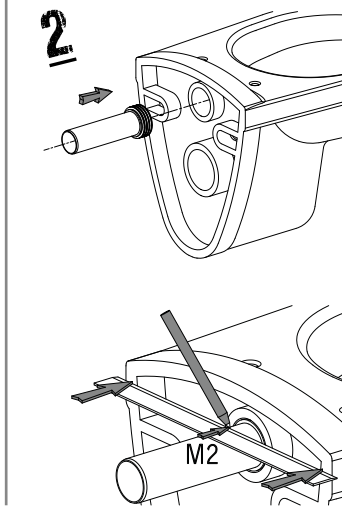
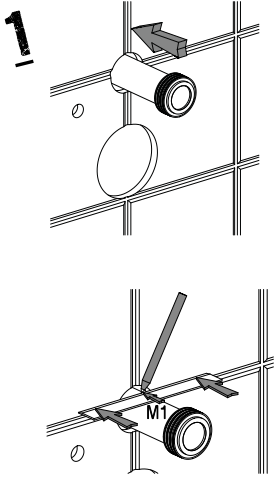

Pour faciliter les opérations graisser les joints d'étanchéité de chaque raccord ou tube.
To facilitate the operations apply some grease to the seals of each fitting or tube.

PURGE & RACCORDEMENT AU ROBINET FLOTTEUR

// CLEAN-UP & FLOAT VALVE CONNECTION

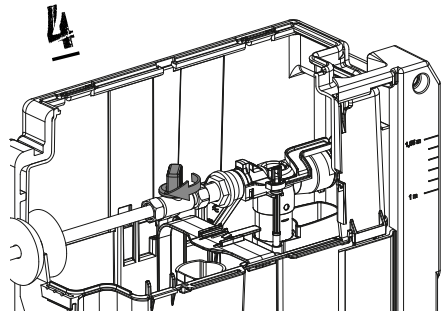
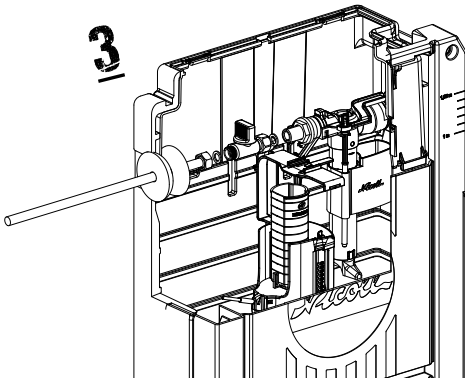
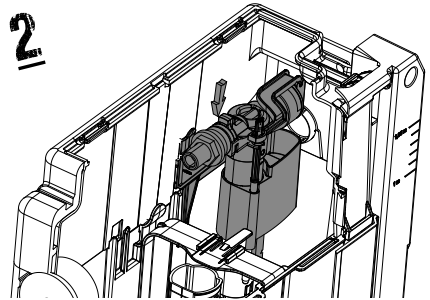
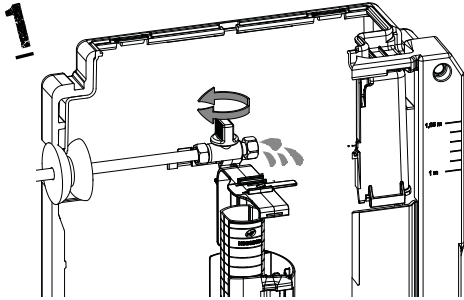

MONTAGE DE LA PLAQUE DE COMMANDE

// CONTROL PLATE ASSEMBLY

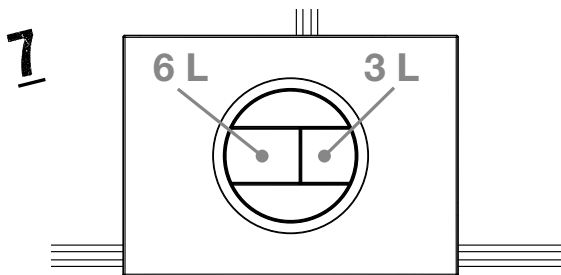
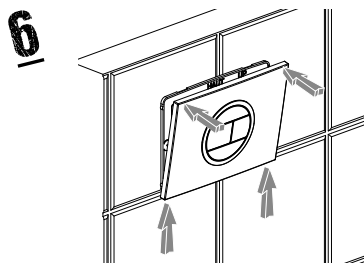
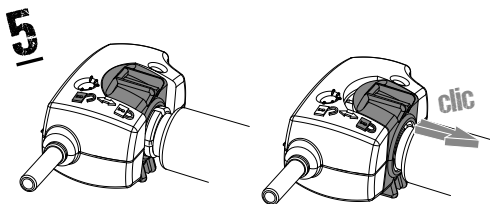
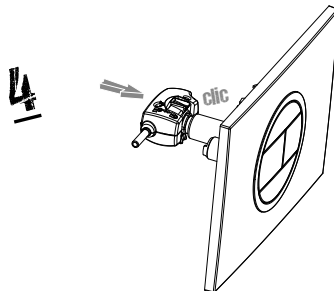
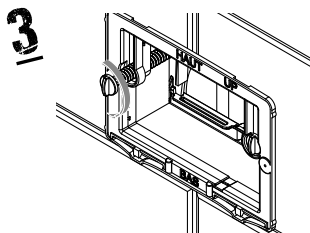
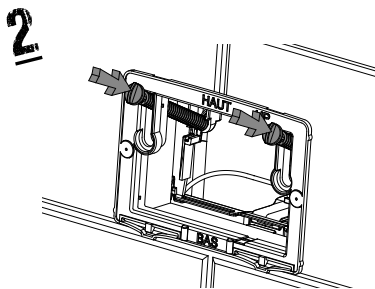
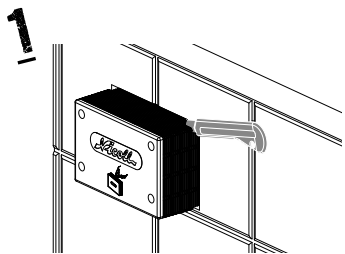

ESSAI DE FONCTIONNEMENT // FUNCTION CHECK

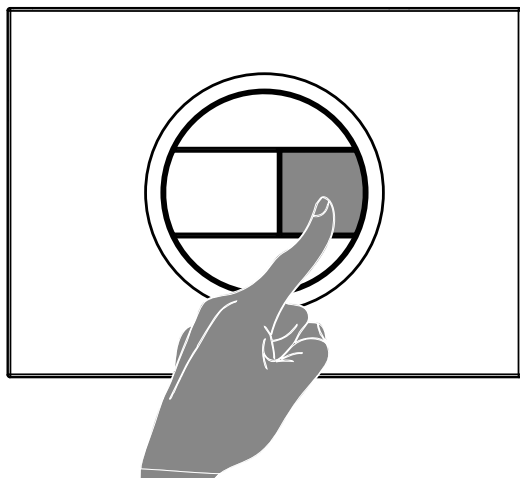

✓
3 L

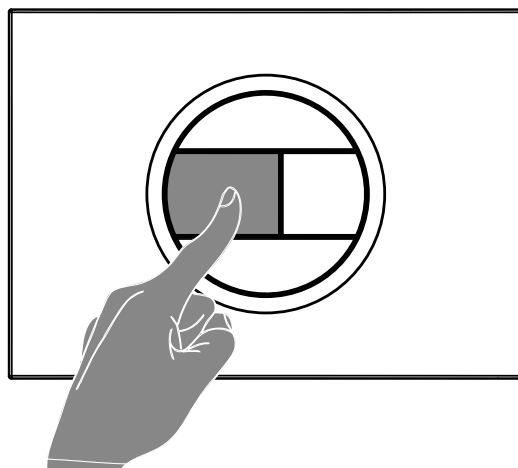

✓
6 L

MAINTENANCE // MAINTENANCE

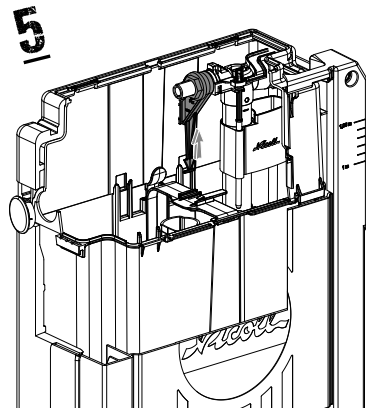
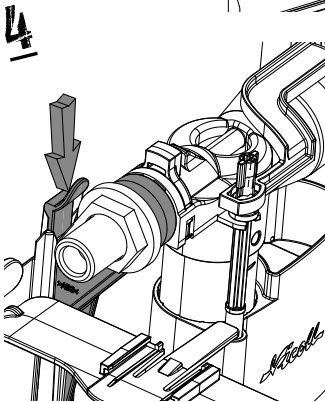
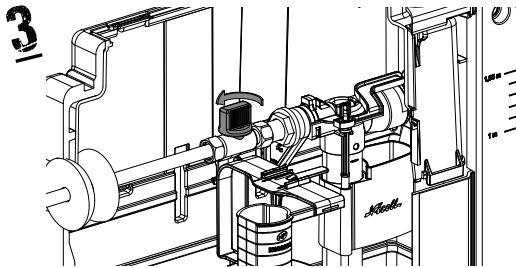
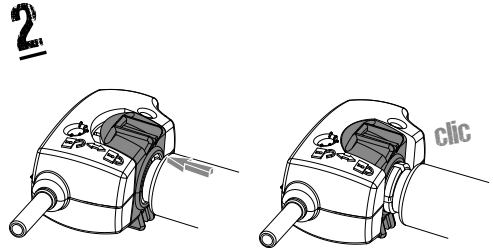
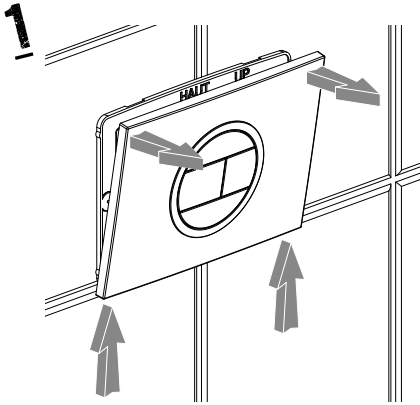

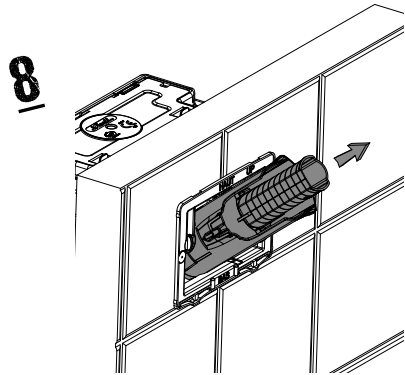
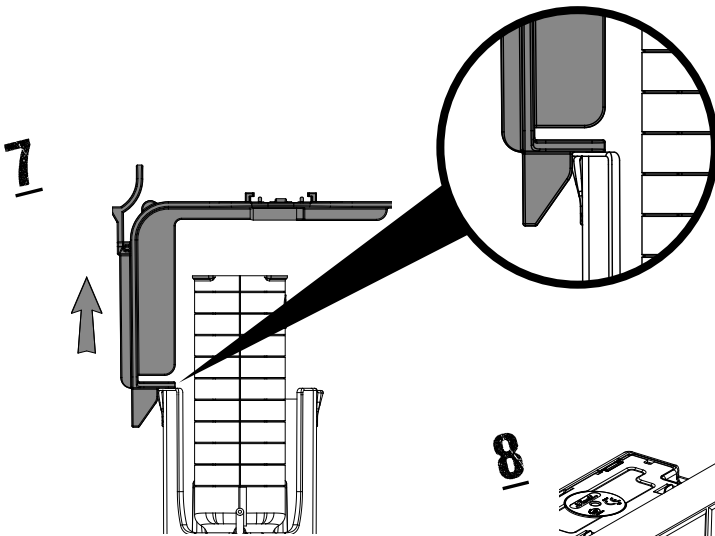
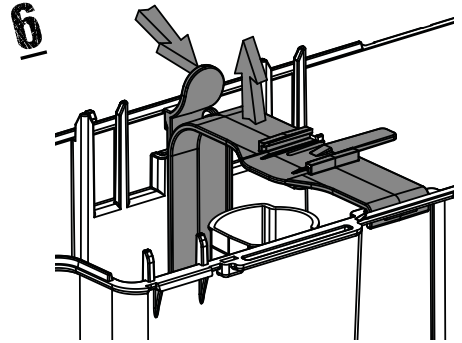
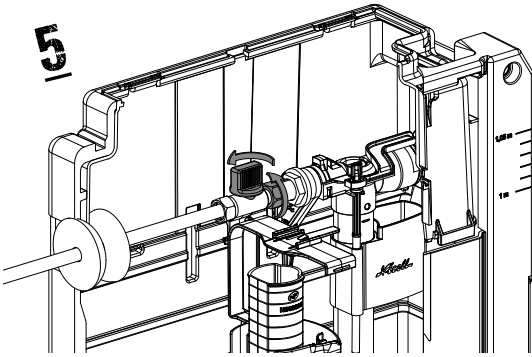



BÂTI-SUPPORT MURAL VIRTUO FIT



Notice de pose

Bâti-support
WBSMU
WBSMUEX



Nicoll
by aliaxis

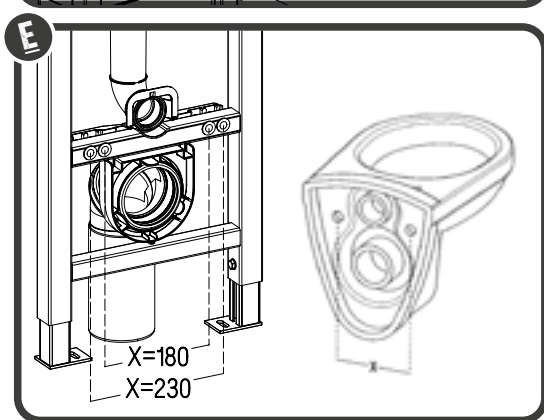
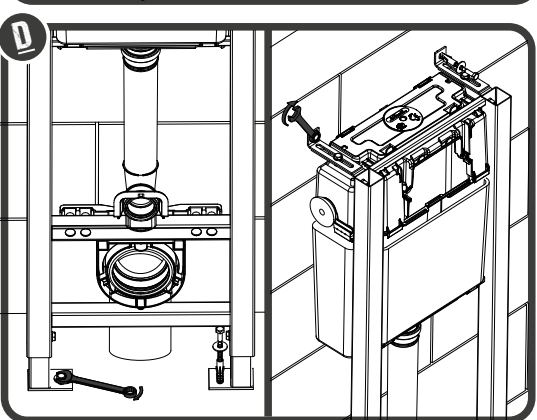
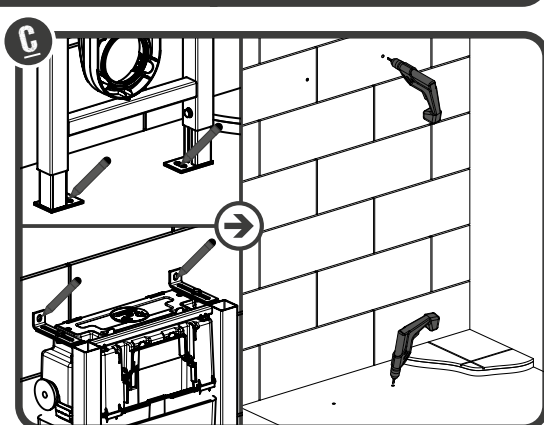
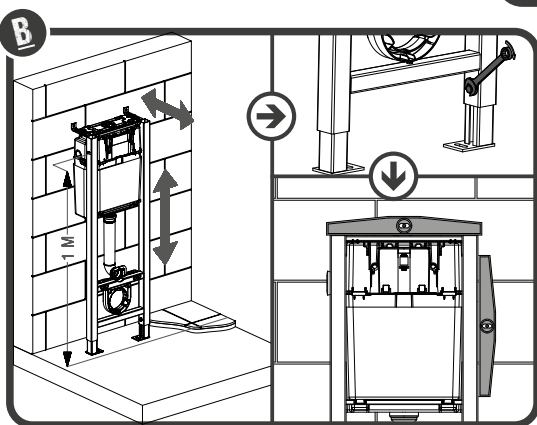
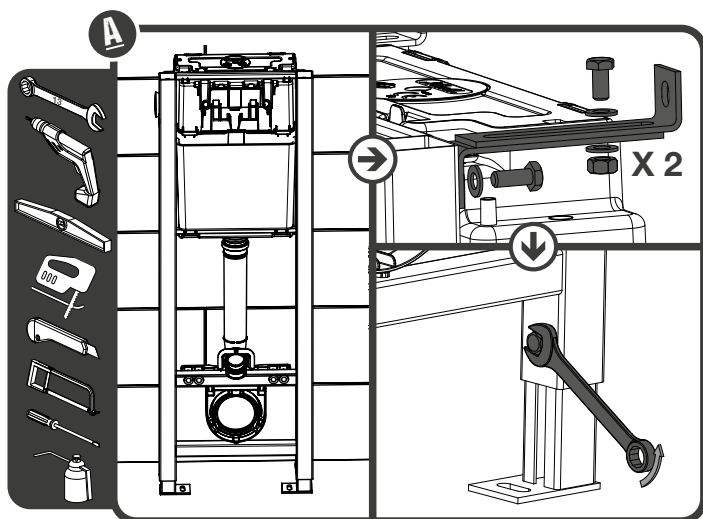
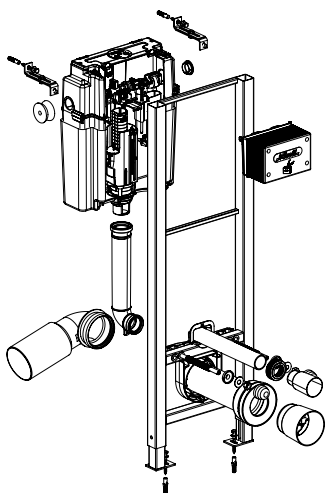

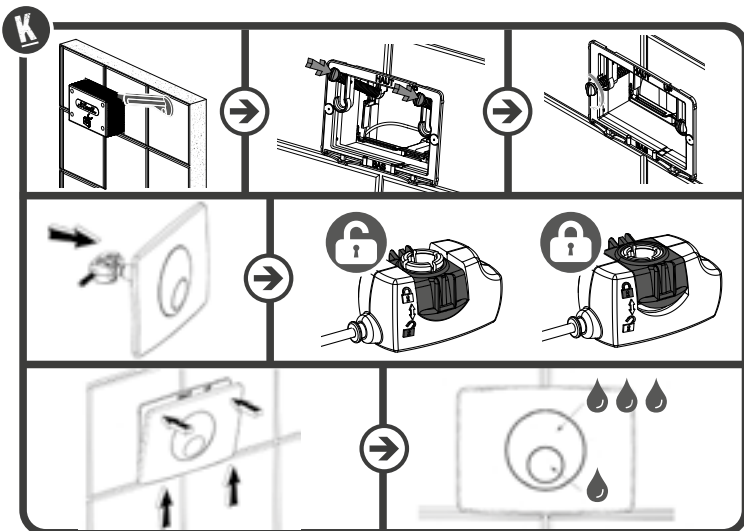
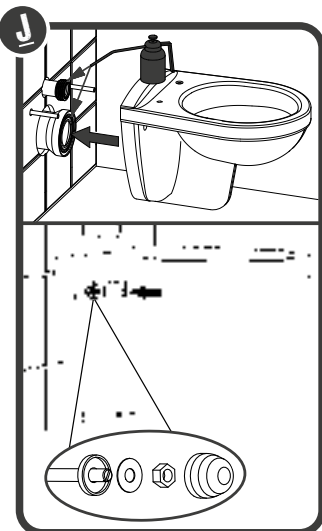
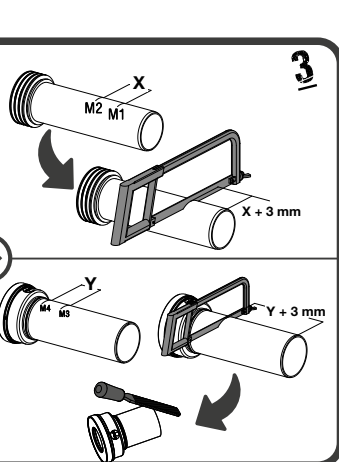
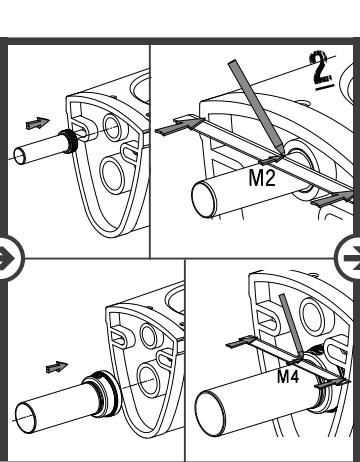
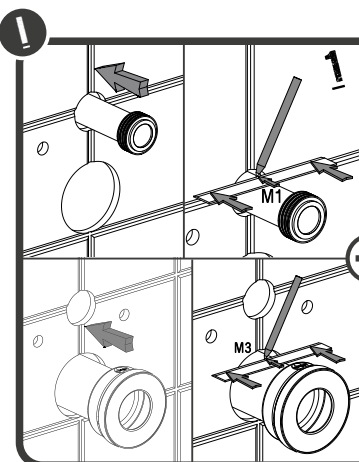
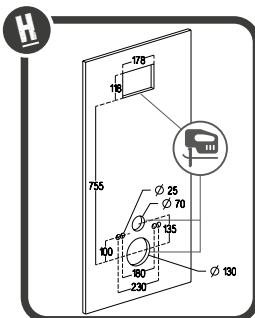
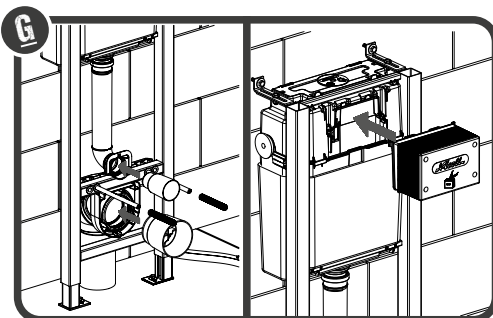
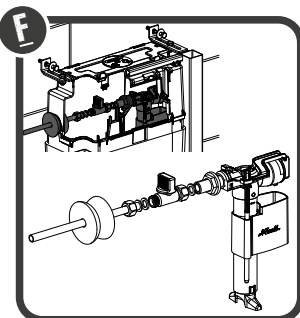

986888-04/23 - Document non contractuel